Operation Manual

Thorlabs Blueline™ Series
PRO8000 (-4) / PRO800

Combi module ITC8xxx



2003

Version: 2.10
Date: 31.10.2003

Contents	Page
1 General description of the combi module ITC8xxx	1
1.1 Safety	1
1.2 Warranty	3
1.3 Features	4
1.3.1 Safety measures for the laser diode and the TEC element	4
1.3.2 General functions	6
1.4 Technical data	8
1.4.1 Common data ITC8xxx	8
1.4.2 ITC8022	10
1.4.3 ITC8052	11
1.4.4 ITC8102	12
1.5 Operating elements at the front of the module	13
1.6 Presettings	14
1.6.1 Hardware limit I_{LIM}	14
1.6.2 Software limits I_{MAX} and $I_{TE LIM}$	15
1.7 Connecting components	16
1.7.1 Pin assignment LD connector	17
1.7.2 Connecting laser- and monitor diode	19
1.7.3 Connecting interlock and status LED	20
1.7.4 Pin assignment TEC connector	21
1.7.5 Connecting a thermistor	22
1.7.6 Connecting an AD590	22
1.7.7 Connecting an LM335	23
1.7.8 Connecting the TEC element	23
1.7.9 Polarity check of the TEC element	24
1.7.10 Connecting the status LED	24
1.7.11 Pin assignment ITC8000-DS15	25
1.8 Optimization of temperature control	26
1.8.1 Setup and function of temperature controllers	26
1.8.2 PID adjustment	27
2 Operating the ITC8xxx	29
2.1 Functions in the main menu	29
2.1.1 Display	29
2.1.2 Selecting a module	30
2.1.3 Setting the main parameter	30
2.2 Functions in the channel menu	32

2.2.1	Display	32
2.2.2	Changing parameters	35
2.2.3	Selecting the polarity of the laser and the monitor diode	36
2.2.4	Calibrating the monitor diode	36
2.2.5	Selecting constant current or constant power mode	37
2.2.6	Selecting the type of the sensor	37
2.2.7	Calibrating the thermistor	38
2.2.8	Setting a temperature window	41
2.2.9	Activating the temperature protection	41
2.2.10	Adjusting the bias voltage for the monitor diode	42
2.2.11	Setting the P-, I- and D-share of the control loop	43
2.3	Switching on and off	44
2.4	Error messages	46
3	Communication with a control computer	48
3.1	General notes on remote control	48
3.1.1	Nomenclature	49
3.1.2	Data format	49
3.2	Commands	51
3.2.1	Select the module slot	51
3.2.2	Calibrating a photo diode (CALPD)	51
3.2.3	Thermistor calibration (exponential method)	52
3.2.4	Thermistor calibration (Steinhart-Hart method)	54
3.2.5	Programming the laser diode current (ILD)	55
3.2.6	Programming the monitor diode current (IMD)	57
3.2.7	Switching the I-share on and off (INTEG)	59
3.2.8	Reading the TEC current (ITE)	59
3.2.9	Switching the laser output on and off (LASER)	60
3.2.10	Selecting the laser diode polarity (LDPOL)	60
3.2.11	Programming the laser diode software-limit (LIMC)	61
3.2.12	Reading the laser diode hardware-limit (LIMCP)	62
3.2.13	Programming the TEC current software-limit (LIMT)	62
3.2.14	Selecting the mode of operation (MODE)	63
3.2.15	Selecting the photo diode polarity (PDPOL)	63
3.2.16	Programming the optical power (POPT)	64
3.2.17	Programming the resistance of the thermistor (RESI)	65
3.2.18	Programming the resistance window (RWIN)	66
3.2.19	Selecting the sensor (SENS)	66
3.2.20	Programming the PID shares (SHAREP, -I, -D)	67
3.2.21	Switching the TEC on and off (TEC)	68

3.2.22	Programming the temperature (TEMP)	69
3.2.23	Switching the temperature protection on and off (TP)	70
3.2.24	Programming the temperature window (TWIN)	71
3.2.25	Read Type of module (TYPE)	71
3.2.26	Programming the bias voltage (VBIAS)	72
3.2.27	Reading the laser diode voltage (VLD)	73
3.2.28	Reading the TEC voltage (VTE)	74
3.3	1301 ... 1316 error messages of the ITC8xxx	75
3.4	Status reporting	77
3.4.1	Standard event status register (ESR)	79
3.4.2	Standard event status enable register (ESE)	79
3.4.3	Status byte register (STB)	80
3.4.4	Service request enable register (SRE)	80
3.4.5	Reading the STB by detecting SRQ	81
3.4.6	Reading the STB by " *STB? " command	81
3.4.7	Reading the STB by serial poll	81
3.4.8	Device error condition register (DEC)	82
3.4.9	Device error event register (DEE)	83
3.4.10	Device error event enable register (EDE)	83
4	Service and Maintenance	84
4.1	General remarks	84
4.2	Troubleshooting	85
5	Listings	89
5.1	List of acronyms	89
5.2	List of figures	91
5.3	Certifications and compliances	92
5.4	Addresses	93

We aim to develop and produce the best solution for your application in the field of optical measurement technique. To help us to come up to your expectations and develop our products permanently we need your ideas and suggestions. Therefore, please let us know about possible criticism or ideas. We and our international partners are looking forward to hearing from you. In the displays shown by the PRO8 you may find the name PROFILE. PROFILE was the name of the manufacturer before it was acquired by Thorlabs and renamed to Thorlabs GmbH.

Thorlabs GmbH

This part of the instruction manual contains every specific information on how to operate a current module ITC8xxx. A general description is followed by explanations of how to operate the unit manually. You will also find every information about remote control via the IEEE 488 computer interface.

Attention

This manual contains “WARNINGS” and “ATTENTION” label in this form to indicate dangers for persons or possible damage of equipment.

Please read these advises carefully!

NOTE

This manual also contains “NOTES” and “HINTS” written in this form.

1 General description of the combi module ITC8xxx

1.1 Safety

Attention

All statements regarding safety of operation and technical data in this instruction manual will only apply when the unit is operated correctly.

Before applying power to your PRO8000 (-4) / PRO800 system, make sure that the protective conductor of the 3 conductor mains power cord is correctly connected to the protective earth contact of the socket outlet!

Improper grounding can cause electric shock with damages to your health or even death!

Modules may only be installed or removed with the mainframe switched off.

All modules must be fixed with all screws provided for this purpose.

Modules of the 8000 series must only be operated in the mainframe PRO8000, PRO8000-4 or PRO800.

All modules must only be operated with duly shielded connection cables.

Only with written consent from Thorlabs may changes to single components be carried out or components not supplied by Thorlabs be used.

This precision device is only dispatchable if duly packed into the complete original packaging including the plastic form parts. If necessary, ask for a replacement package.

Attention

Laser modules can deliver up to several 100mW of (maybe) invisible laser radiation!

When operated incorrectly, this can cause severe damage to your eyes and health!

Be sure to pay strict attention to the safety recommendations of the appropriate laser safety class!

This laser safety class is marked on your PRO8000 (-4) / PRO800 plug-in module or on your external laser source used.

Attention

Mobile telephones, cellular phones or other radio transmitters are not to be used within the range of three meters of this unit since the electromagnetic field intensity may then exceed the maximum allowed disturbance values according to EN 50 082-1.

1.2 Warranty

Thorlabs GmbH warrants material and production of the ITC8xxx modules for a period of 24 months starting with the date of shipment. During this warranty period *Thorlabs GmbH* will see to defaults by repair or by exchange if these are entitled to warranty.

For warranty repairs or service the unit must be sent back to *Thorlabs GmbH (Germany)* or to a place determined by *Thorlabs*. The customer will carry the shipping costs to *Thorlabs GmbH*, in case of warranty repairs *Thorlabs* will carry the shipping costs back to the customer.

If no warranty repair is applicable the customer also has to carry the costs for back shipment.

In case of shipment from outside EU duties, taxes etc. which should arise have to be carried by the customer.

Thorlabs GmbH warrants the hard- and software determined by *Thorlabs GmbH* for this unit to operate fault-free provided that they are handled according to our requirements. However, *Thorlabs GmbH* does not warrant a faulty free and uninterrupted operation of the unit, of the soft- or firmware for special applications nor this instruction manual to be error free. *Thorlabs GmbH* is not liable for consequential damages.

Restriction of warranty

The warranty mentioned before does not cover errors and defects being the result of improper treatment, software or interface not supplied by us, modification, misuse or operation outside the defined ambient conditions (refer to the PRO8000 (-4) / PRO800 mainframe operation manual) stated by us or unauthorized maintenance.

Further claims will not be consented to and will not be acknowledged. *Thorlabs GmbH* does explicitly not warrant the usability or the economical use for certain cases of application.

Thorlabs GmbH reserves the right to change this instruction manual or the technical data of the described unit at any time.

1.3 Features

1.3.1 Safety measures for the laser diode and the TEC element

To protect the connected laser diodes and the TEC elements the combi controller ITC8xxx contains the following protection circuits:

- **Softstart when switching on the laser diode current**
Protection against capacitive and inductive parasitic elements (switching peaks).
- **Software limit for the injection current and the TEC element in all operating modes and additional hardware limit for the injection current**
Protection against thermal destruction of the devices.
- **Interruption control of the connection cable to the laser diode (interlock)**
Protection against accidental operation.
- **Contact protection of the laser diode (open circuit)**
Protection against cable damage or bad contact.
- **Electronic short-circuit switch for the laser diode**
Protection against static discharge when touching the switched off laser.
- **Protection of the sensor**
Protection against the use of an wrong temperature sensor / protection against line interruption to the temperature sensor.
- **Separate on and off function for each module**
Protection against operating errors.
- **Separate over-temperature protection for each module**
Protection against thermal failure of the module.
- **Control LED for the laser and/or TEC current active**

Mains filter

Protection against line transients and interferences.

- **Line failure protection**

In case of line failure/line damage the combi module must explicitly be switched on anew since it cannot be taken for granted that all components of the measurement setup are still working faultlessly.

- **Key-operated power switch**

Protection against unauthorized or accidental use.

- **Action check**

After power up the combi modules are in LASER OFF mode.

- **LabVIEW®- and LabWindows/CVI®-driver**

For the PRO8000 (-4) / PRO800 Thorlabs supplies LabVIEW®- and LabWindows/CVI®-drivers for MS Windows 32.

.Please refer to our homepage for the latest driver updates.

<http://www.thorlabs.com>

1.3.2 Ordering Codes:

ITC8022	± 200 mA module with 9-pin and 15-pin D-Sub connector
ITC8022DS15	Only one common 15-pin connector for laser diode and TEC
ITC8052	± 500 mA module with 9-pin and 15-pin D-Sub connector
ITC8052DS15	Only one common 15-pin connector for laser diode and TEC
ITC8102	± 1 A module with 9-pin and 15-pin D-Sub connector
ITC8102DS15	Only one common 15-pin connector for laser diode and TEC

1.3.3 General functions

The combi modules ITC8xxx are bipolar current sources for laser diodes combined with a thermoelectric controller. The different module types operate the same way, they only differ in maximum current, resolution and accuracy.

→ (Refer to chapter 1.4, "Technical data" starting on page 8)

The combi modules ITC8xxx contain a transimpedance amplifier input for the monitor diode (input impedance 0Ω). Both polarities of the monitor diode are allowed. The monitor diode may be operated either photovoltaic (without bias voltage) or photoconductive, i.e. with bias voltage.

All modules are equipped with an input for either IC temperature sensors of the AD590/592 , LM335 series or thermistors, PT modules have only an input for thermistors and PT100 elements..

All necessary value settings are done by keypad and rotational encoder or via remote control by a computer. Only the laser diode current limit (hardware limit) has to be set manually as "absolute limit".

In an automated test set-up for different laser diodes no manual settings are required.

With the modules ITC8xxx, the laser diode current in constant current mode, the monitor diode current in constant power mode, and temperature or thermistor resistance are set with a resolution of 16 bit.

The limit values for the laser diode current (software limit), the monitor diode current (limiting the optical output power) and the limit value for the TEC current (software limit) are set with a resolution of 12 bit. The monitor diode current, the actual temperature and actual resistance are read back with 16 bit, the laser diode current, laser diode voltage, the limit for the laser diode current (hardware limit), the TEC current and TEC voltage with 15 bit plus sign.

The P-, I- and D-share of the analog control loop are set via three independent 12 bit D/A converters.

The built-in mains filter in the mainframe and the careful shielding of the transformer, the micro processor and the module itself provide an excellent suppression of noise, ripple and other interferences.

1.4 Technical data

1.4.1 Common data ITC8xxx

Resolution 16 Bit

Power control

Range of monitor current I_{PD} 10 μ A ... 2 mA¹⁾

Resolution 30 nA

Setting accuracy (typ.) ± 0.1 % fs

Drift (30 min. without changing the ambient temperature.) ≤ 1 μ A

Photodiode bias voltage 0 ... 10 V

Laser voltage

Measurement principle 4-wire

Measurement range 0 ... 10 V

Resolution 0.3 mV

Accuracy ± 5 mV

AD590/LM335

Control range -12.375 °C ... +90.000 °C

Measurement accuracy ± 0.1 °C

Measurement resolution 0.0015 °C

Setting accuracy 0.01 °C

Setting resolution 0.0015 °C

Temperature stability typ. < 0.002 °C

Thermistor (calibrated and not calibrated, display in Ω)

Measurement current 50 μ A

Control range 200 Ω ... 40 k Ω

Resolution 0.7 Ω

Setting accuracy ± 10 Ω

Resistance stability typ. ≤ 1 Ω

Thermistor (calibrated, display in °C)

Measurement current	50 μ A ¹⁾
Control range	temperature at 40 k Ω ... 150 °C ²⁾
Resolution	2)
Setting accuracy	2)
Temperature stability	2)

PID-control

P-, I-, and D-share	to be set separately
Setting range	2.5 ... 100 %

Warm-up time for rated accuracy	\leq 15 min
Width of module	1 Slot
LD-Connector	9-pin D-sub
TEC-Connector	15-pin D-sub

¹ other ranges on request

² depending on thermistor data

1.4.2 ITC8022

Current control

Range of laser current I_{LD}	0 ... ± 200 mA
Compliance voltage	> 5 V
Setting resolution	3 μ A
Setting accuracy (typ.)	0.05% fs
Measurement resolution	6 μ A
Noise without ripple (10 Hz ... 10 MHz, rms)	< 2 μ A
Ripple (50 Hz, rms)	< 1 μ A
Transients (processor)	< 15 μ A
Transients (other, typ. ¹⁾)	< 200 μ A
Short-term fluctuations (15 s, 0 ... 10 Hz)	≤ 2 μ A
Drift (30 min. without changing the ambient temperature)	≤ 5 μ A
Temperature coefficient	≤ 50 ppm/ $^{\circ}$ C

LD Current limit

Setting range poti I_{LIM}	0 ... ≥ 200 mA
Setting range software I_{MAX}	0 ... ≥ 200 mA
Setting resolution	6 μ A
Setting accuracy	± 200 μ A

Current output TEC element

Control range	- 2 A ... + 2 A
Maximum output power	16 W
Compliance voltage	> 8 V
Measurement resolution I_{TE}	0.07 mA
Measurement resolution U_{TE}	0.3 mV
Noise and ripple	< 1 mA

TEC Current limit

Setting range	0 ... ≥ 2 A
Setting accuracy (software)	± 20 mA
Resolution	0.5 mA

¹⁾ max. transients at the output, e.g. switching the unit on or off

1.4.3 ITC8052

Current control

Range of laser current I_{LD}	0 ... ± 500 mA
Compliance voltage	> 5 V
Setting resolution	7.5 μ A
Setting accuracy	0.05% fs
Measurement resolution	15 μ A
Noise without ripple (10 Hz ... 10 MHz, rms)	< 5 μ A
Ripple (50 Hz, rms)	< 1 μ A
Transients (processor)	< 30 μ A
Transients (other, typ. ¹⁾)	< 500 μ A
Short-term fluctuations (15 s, 0 ... 10 Hz)	≤ 6 μ A
Drift (30 min. without changing the ambient temperature)	≤ 12 μ A
Temperature coefficient	≤ 50 ppm/ $^{\circ}$ C

LD Current limit

Setting range poti I_{LIM}	0 ... ≥ 500 mA
Setting range software I_{MAX}	0 ... ≥ 500 mA
Setting resolution	15 μ A
Setting accuracy	± 0.5 mA

Current output TEC element

Control range	- 2 A ... + 2 A
Maximum output power	16 W
Compliance voltage	> 8 V
Measurement resolution I_{TE}	0.07 mA
Measurement resolution U_{TE}	0.3 mV
Noise and ripple	< 1 mA

TEC Current limit

Setting range	0 ... ≥ 2 A
Setting accuracy (software)	± 20 mA
Resolution	0.5 mA

¹⁾ max. transients at the output, e.g. switching the unit on or off

1.4.4 ITC8102

Current control

Range of laser current I_{LD}	0 ... ± 1 A
Compliance voltage	> 5 V
Setting resolution	15 μ A
Setting accuracy	0.1% fs
Measurement resolution	30 μ A
Noise without ripple (10 Hz ... 10 MHz, rms)	< 10 μ A
Ripple (50 Hz, rms)	< 1.5 μ A
Transients (processor)	< 50 μ A
Transients (other, typ. ¹⁾)	< 1 mA
Short-term fluctuations (15 s, 0 ... 10 Hz)	≤ 12 μ A
Drift (30 min. without changing the ambient temperature)	≤ 25 μ A
Temperature coefficient	≤ 50 ppm/ $^{\circ}$ C

LD Current limit

Setting range poti I_{LIM}	0 ... ≥ 1 A
Setting range software I_{MAX}	0 ... ≥ 1 A
Setting resolution	30 μ A
Setting accuracy	± 2 mA

Current output TEC element

Control range	- 2 A ... + 2 A
Maximum output power	16 W
Compliance voltage	> 8 V
Measurement resolution I_{TE}	0.07 mA
Measurement resolution U_{TE}	0.3 mV
Noise and ripple	< 1 mA

TEC Current limit

Setting range	0 ... ≥ 2 A
Setting accuracy (software)	± 20 mA
Resolution	0.5 mA

¹⁾ max. transients at the output, e.g. switching the unit on or off

1.5 Operating elements at the front of the module

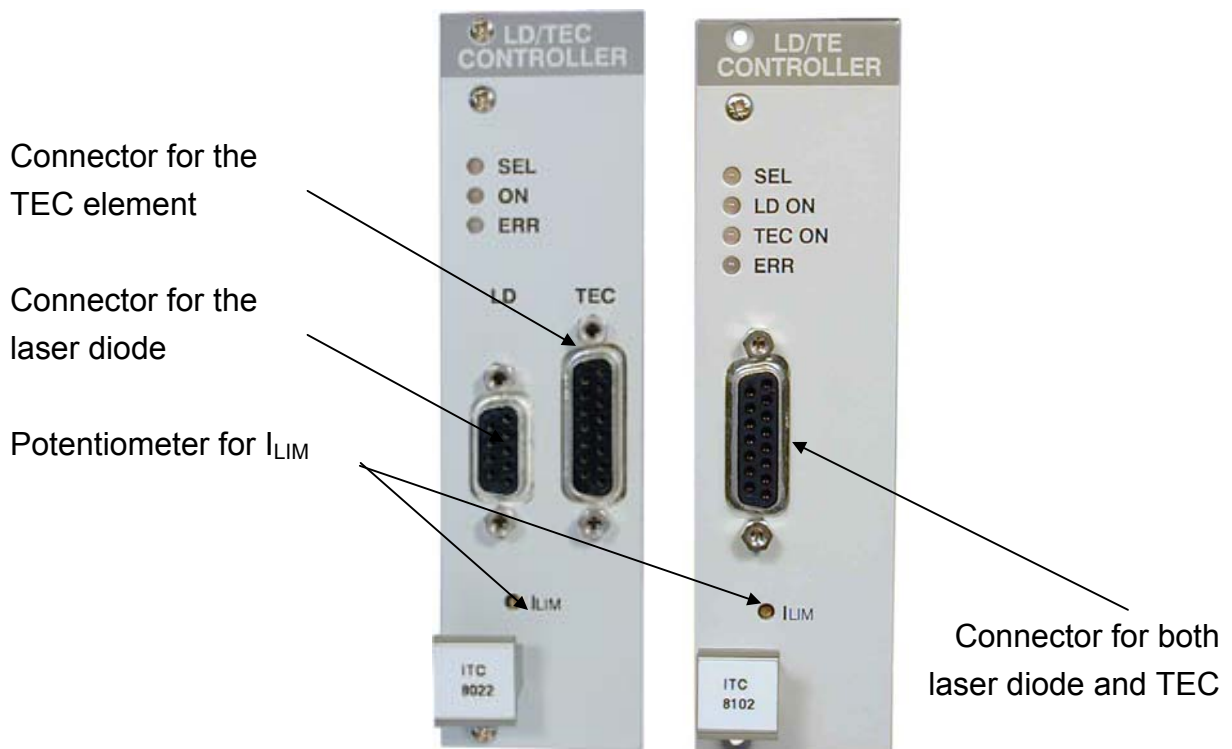

Figure 1 The ITC8xxx and ITC8xxxDS15 front panel

1.6 Presettings

To protect the laser diode and the TEC element the maximum possible output currents of the module can be limited. Three limit values are used: hardware limit I_{LIM} , software limit I_{MAX} and software limit $I_{TE LIM}$.

1.6.1 Hardware limit I_{LIM}

The hardware limit I_{LIM} , for the laser diode current is set with the potentiometer marked I_{LIM} at the front panel of the ITC8.

→ (Refer to chapter 1.5, "Operating elements at the front of the module" on page 13)

The value is displayed continually in the channel menu of the module so you can watch it during adjustment:

→ (Refer to chapter 2.2, "Functions in the channel menu" starting on page32)

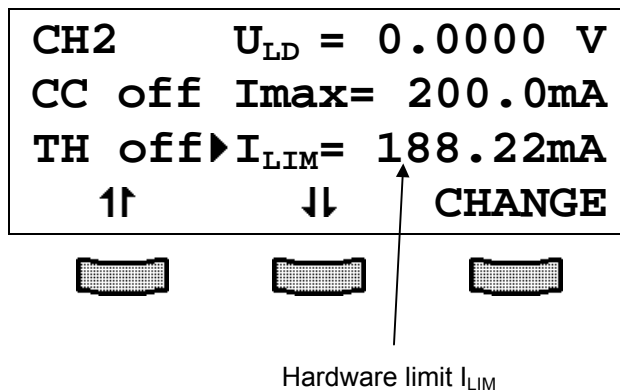

1.6.2 Software limits I_{MAX} and $I_{TE LIM}$

The software limits I_{MAX} and $I_{TE LIM}$ are set and changed in the channel menu of the module or via the IEEE 488 interface.

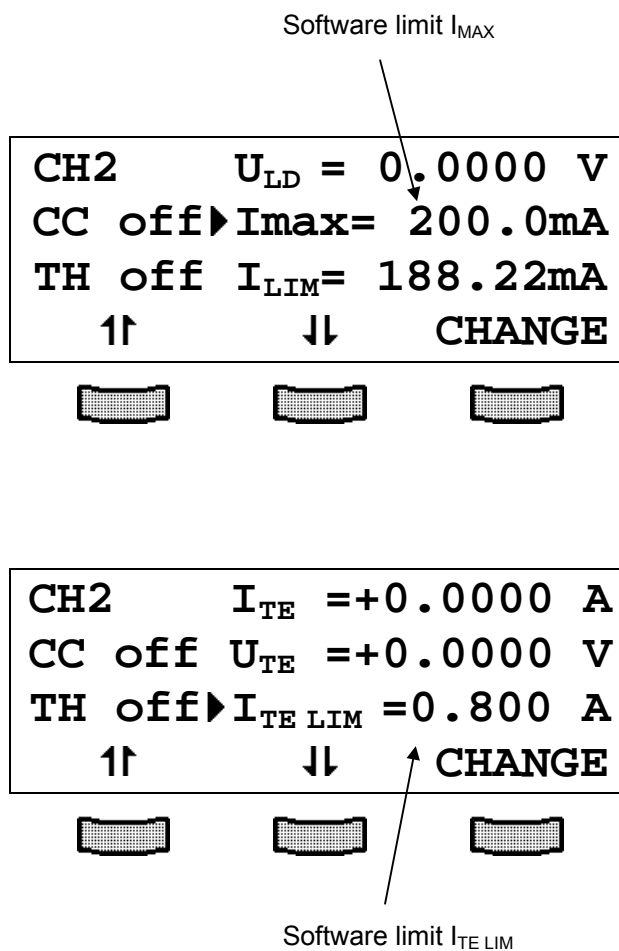

The software limits I_{MAX} and $I_{TE LIM}$ have exactly the same protective function as the hardware limit.

→ (Refer to chapter 2.2, "Functions in the channel menu" starting on page 32)

NOTE

The lower of the two limits I_{MAX} or I_{LIM} will limit the laser diode current.

1.7 Connecting components

Mostly the following components are installed together with the laser:

- Laser diode
- Monitor diode
- TEC element for chip temperature control
- Temperature sensor

The laser diode and the TEC element are always sourced relative to ground by the combi module.

This is of considerable advantage regarding the safety of devices and stability of currents.

The monitor diode input is a trans-impedance amplifier input with virtual ground (input impedance 0Ω).

The monitor diode input can be operated without or with bias voltage (0 V...10 V). The polarity for the monitor diode must be set correspondingly.

→ (Refer to 2.2.10, "Adjusting the bias voltage for the monitor diode" on page 42)

The sensor input can handle different types of sensors.

A missing sensor or selection of a wrong type is detected by the ITC8xxx.

1.7.1 Pin assignment LD connector

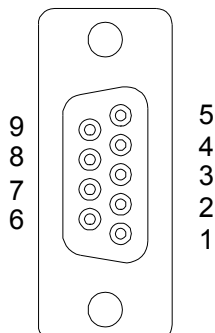

Figure 2 Pin assignment of the laser diode connector (female)

<u>Pin</u>	<u>Function</u>
Interlock, status LED	
1	output for interlock and status LASER ON/OFF
5	ground for pin 1
Laser diode	
7	laser diode cathode (with polarity AG)
8	laser diode anode (with polarity CG)
3	laser diode ground
Monitor diode	
4	monitor diode input
2	monitor diode ground
Measurement input for laser diode voltage	
9	laser diode anode
6	laser diode cathode

We recommend to use separate lines drilled in pairs (twisted pair) in a common shield for laser diode current, monitor diode current and laser voltage measurement. The shield has to be connected to ground (pin 3).

If an external monitor diode is used, it must be connected with a coaxial cable with the outer conductor to pin 2 and the inner conductor to pin 4.

1.7.2 Connecting laser- and monitor diode

Connect laser and monitor diode to the connector of the ITC8xxx.

The wires for voltage measurement of the laser diode (pin 6 and pin 9) should be connected as close as possible to the laser diode to avoid measurement errors.

The ground conductor of the monitor diode (pin 2) may be connected to the ground conductor of the laser diode (pin 3). If this is necessary (e.g. with laser diodes with integrated monitor diode and shared ground connector) the ground conductors should be connected as close as possible to the laser diode to avoid measurement errors when measuring the monitor diode current.

In this case the following pin assignments of the output jack are possible:
(shown without voltage measurement)

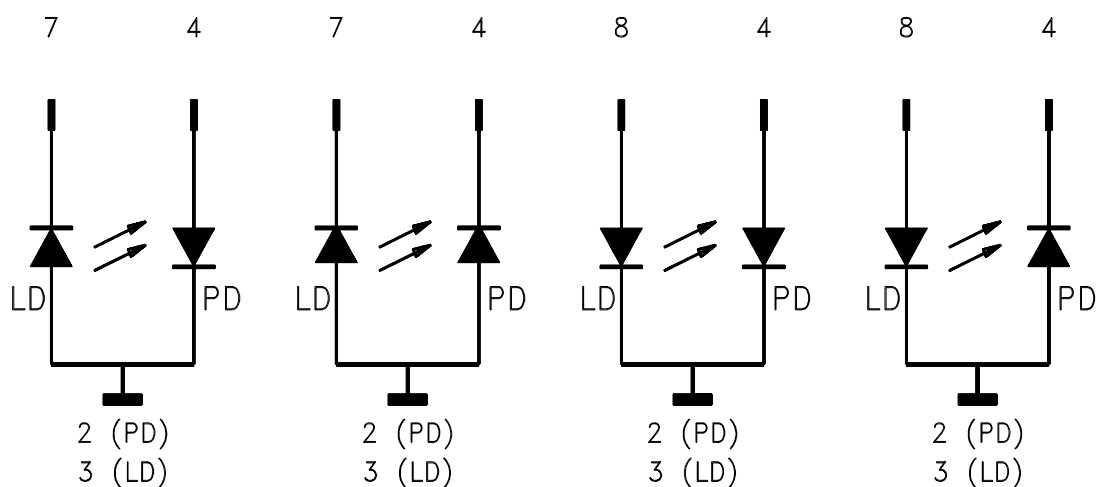

Figure 3 Pin assignments of laser- and photodiode

(LD) = laser diode

(PD) = monitor (photo-) diode

1.7.3 Connecting interlock and status LED

Pin 1 and pin 5 of the connector jack serve as safety connectors to determine whether the current output for the laser diode may be switched on. A short-circuit or at least a low resistance ($R < 430 \Omega$) must be maintained between the two pins. With the contacts open or resistance too high the current module cannot be switched on. Should the interlock contact open during operation the output will be switched off immediately.

Status display

It is also possible to use a LED with a $0.5 \text{ k}\Omega$ resistor in parallel between the two pins. The LED will light up if the current output is switched on. Here are the two possibilities for the pin assignment:

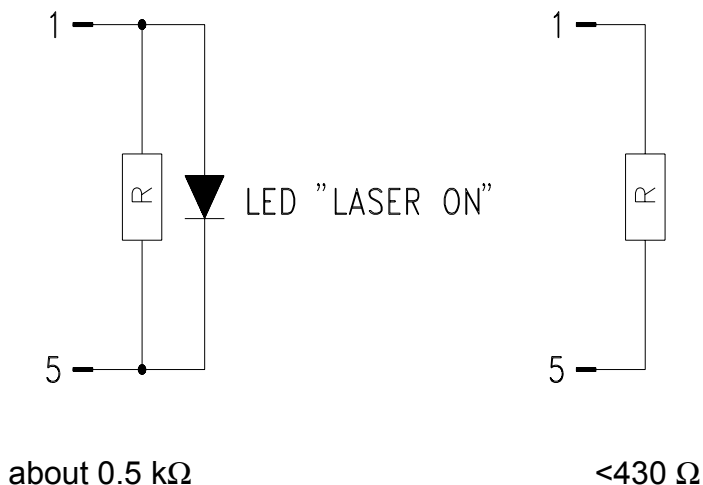

NOTE

Using a resistor above 430Ω - without LED (or if the LED is incorrectly poled) may lead to malfunction as the status of the interlock is then undefined.

1.7.4 Pin assignment TEC connector

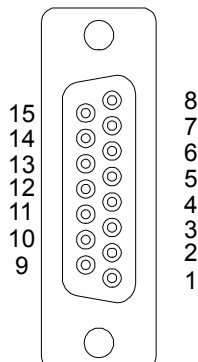

Figure 4 Pin assignment of the TEC connector (female)

<u>Pin</u>	<u>Function</u>
TEC element	
5,6	TEC element +
13,14,15	TEC element - (ground)
Status LED	
1	Status-LED anode
8	Status-LED cathode (ground)
Temperature sensor	
3	Thermistor - (ground)
4	Thermistor +
10	AD590 – (PT100 for ITC8xxxPT)
11	AD590 + (PT100 for ITC8xxxPT)

Connect the TEC element and the temperature sensor with shielded cables to the TEC connector.

The shielding of the cable must be connected to ground (pin 13,14,15).

1.7.5 Connecting a thermistor

The thermistor is connected between pin 3 and pin 4.

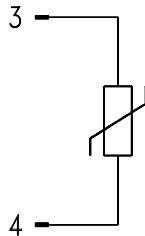

Figure 5 Connecting a thermistor

1.7.6 Connecting an AD590

The IC-temperature sensor AD590 is connected between pin 10 (-) and pin 11 (+).

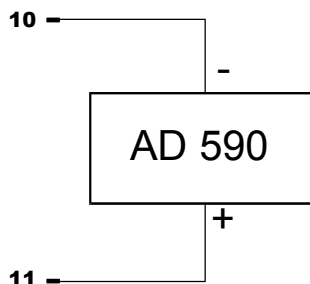

Figure 6 Connecting an AD590

1.7.7 Connecting an LM335

The IC-temperature sensor LM335 is connected between pin 10, pin 11 (+) and pin 8 (-).

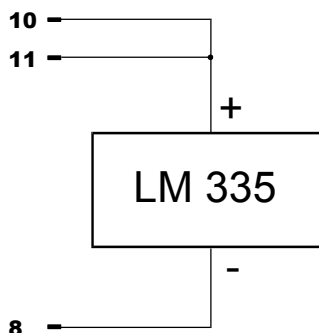

Figure 7 Connecting an LM335

1.7.8 Connecting the TEC element

Connect the TEC element to pins 5 and 6 (+) and the pins 13,14 and 15 for (-).

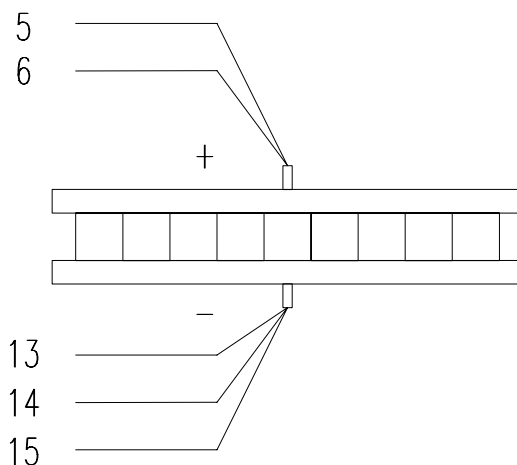

Figure 8 Connecting a TEC element

Attention

An reverse poled TEC element may lead to thermal runaway and destruction of the connected components.

→ Refer to chapter 1.7.9, "Polarity check of the TEC element" starting on page 24.

1.7.9 Polarity check of the TEC element

Presettings

- Connect TEC element and temperature sensor. The sensor must have good thermal contact to the active surface of the TEC element.
- Switch on the laser diode control system PRO8000 (-4) / PRO800.
- Select the ITC8xxx module.
- Select the correct type of sensor.
- Set the appropriate value for I_{MAX} .

Polarity check of the TEC element

- Observe T_{ACT} (or R_{ACT}) and switch on the module by pressing the key "ON/OFF".
- If T_{ACT} (or R_{ACT}) runs away from T_{SET} (or R_{SET}), the TEC element is reverse poled. Change polarity and repeat the procedure.
- If T_{ACT} (or R_{ACT}) is oscillating around the value T_{SET} (or R_{SET}) the TEC element is connected correctly, but the P-, I- and D-share values of the control loop are still incorrect.
- If T_{ACT} (or R_{ACT}) is settling properly to the value T_{SET} (or R_{SET}) the TEC element has been connected correctly, the values for the P-, I- and D-share of the control loop might still be improved.

→ (Refer to chapter 1.8.2, "PID adjustment" starting on page 27)

1.7.10 Connecting the status LED

To display the operating status a standard LED may be used between pin 1 and pin 8. The LED will light up if the output for the TEC current is switched on.

1.7.11 Pin assignment ITC8xxxDS15

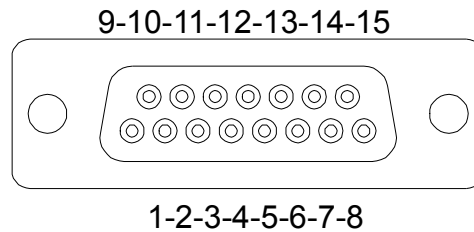

Figure 9 ITC8xxxDS15 D-SUB I/O jack (female)

<u>PIN</u>	<u>Function</u>
8	TEC - (ground)
7	TEC +
6	AD 590 +
13	AD 590 -
14	Thermistor ground
15	Thermistor
11	Laser diode anode (polarity CG)
3	Laser diode ground
10	Laser diode cathode (polarity AG)
2	Monitor diode ground
4	Monitor diode anode or cathode
9	$U_{LD} -$ (cathode)
12	$U_{LD} +$ (anode)
1	Interlock
5	Interlock ground

1.8 Optimization of temperature control

1.8.1 Setup and function of temperature controllers

When diode laser systems are tempered mainly the following components are involved:

- The component to be tempered (laser diode)
- A sensor measuring the temperature of the component (thermistor / AD590 / LM335)
- A heat source or sink (air or water / cooling element)
- A heat conductor connecting the component to the source/sink (copper, aluminum)
- A "propulsion" to lead the thermal flow (TEC element)

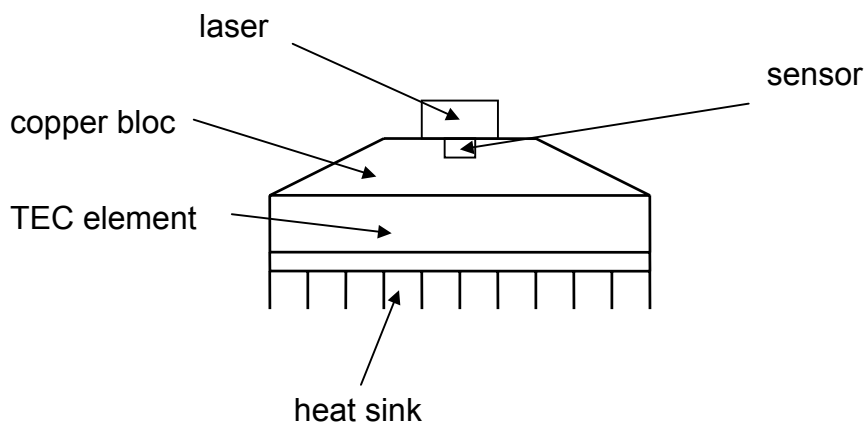

Figure 10 Principle set-up of laser temperature control

Influences on the real temperature control loop

To 1: Offset and gain errors of the sensor allow only an estimate of the laser temperature.

The sensor is never fixed directly to the laser chip to measure its "real" temperature. The inhomogeneous temperature in the copper bloc will influence the measurement. Even within the laser chip you will find a temperature gradient.

Possible optimization: calibration of sensor

To 2. If the internal power dissipation in the laser changes (e.g. the laser current is changed) also the temperature gradient between laser and sensor will change. This results in a measurement error depending on the mechanical set-up laser/sensor. Slow changes of the ambient temperature, however, will be compensated well by the control loop since the retroaction of the air on the laser diode can be neglected.

Possible solution: optimized thermal design

To 3. The transient response by setting a new temperature is limited since the heat transport in the copper bloc is relatively slow. Furthermore, the temperature slope in the copper must stabilize anew. The sensor must settle to the laser temperature - it also has a non negligible heat capacity.

Possible optimization: careful adjustment of PID parameters

1.8.2 PID adjustment

Temperature control loops are comparatively slow with control oscillations in the Hertz range.

The PID adjustment will optimize the dynamic behavior. With the TED8xxx the three parameters P, I and D can be set independently from 0.1% to 100%.

Example of a PID adjustment

(Pre-conditions: All limit values have been set correctly, all polarities are correct, all relevant calibration values are entered)

- Switch off the I-share.
- Set the P-, I- and D-share to 1%.

→ (refer to section 2.2.11, "Setting the P-, I- and D-share of the control loop" on page 43)

- Switch on the output and observe the temperature.

P-share

- Change repeatedly between set temperatures of 18 °C and 22 °C while observing the settling behavior of the actual temperature.
Increase the P-share gradually. Higher values will increase the settling speed, too high values make the system oscillate.
The P-share has been set correctly when the actual temperature remains stable near the set temperature after only 2-3 overshoots.

D-share

- Change repeatedly between set temperatures of 18 °C and 22 °C while observing again the settling behavior of the actual temperature.
Increase the D-share gradually. Higher values will decrease the amplitude of the overshoots.
The D-share is set correctly when the actual temperature remains stable near the set temperature after a minimum of overshoots.

I-share

- Turn on the I-share again.
- Again change repeatedly between set temperatures of 18 °C and 22 °C.
Increase the I-share gradually. Higher values will accelerate the settling to the set temperature.
The I-share is set correctly when the actual temperature reaches the set temperature in shortest time without overshoots.

2 Operating the ITC8xxx

→ Before switching on the laser current please refer to chapter 1.6, "Presettings" on page 14

NOTE

With modules of the ITC8xxx series all settings are executed at once. It is not necessary to confirm the set values.

2.1 Functions in the main menu

2.1.1 Display

The main menu shows the channel number and the two most important operating parameters of the ITC8xxx module.

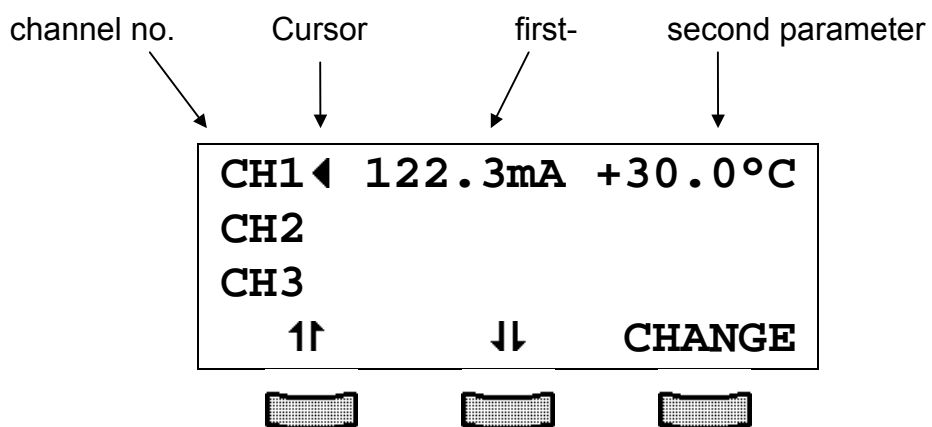

In constant current mode the first parameter is the laser current I_{LD} in mA or A and the second value is the temperature T in °C.

In constant power mode the first parameter is the optical power P_{LD} in mW and the second value is the temperature T in °C.

If the LD and TEC controllers are switched off, the set values ($I_{LD}/P_{LD}/T_S$) are displayed. If one or both controllers are turned on the corresponding actual values appear ($I_{LD}/P_{LD}/T_A$).

2.1.2 Selecting a module

To select a module move the cursor with the softkeys \uparrow and \downarrow to the desired channel number.

CH2 \leftarrow

Pressing  will lead to the channel menu

→ (Refer to chapter 2.2, "Functions in the channel menu" starting on page 32)

2.1.3 Setting the main parameter

To set the main parameter move the cursor to the desired channel number (here: CH1):

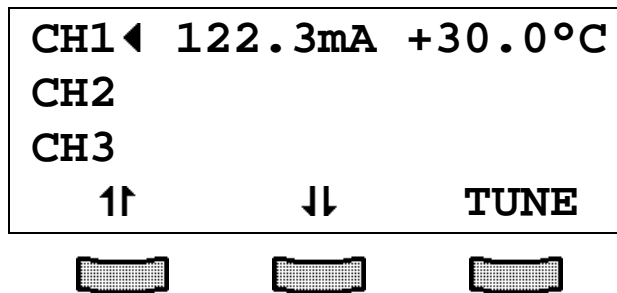

Press the softkey (**TUNE**) to turn the cursor to the right:

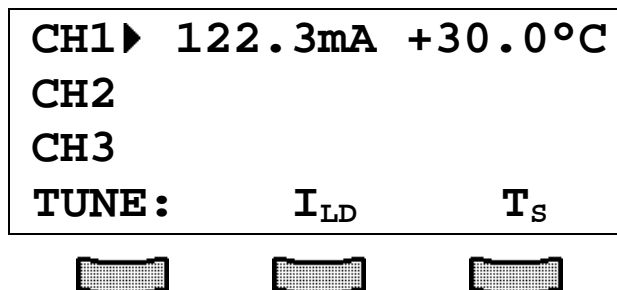

Adjust the main parameter, here the laser diode current I_{LD} , with the tuning knob.

To change the set temperature use the softkey (T_S).

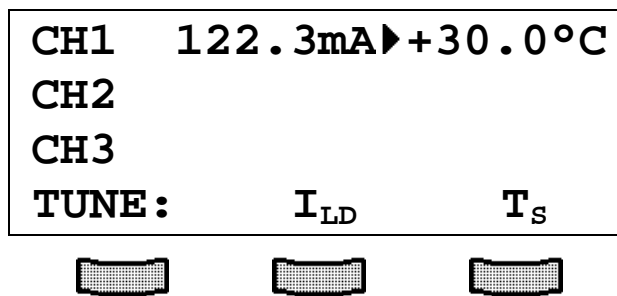



Press  to end the procedure.

NOTE

If the TEC current is switched ON, the actual temperature is displayed. In this case the set temperature can still be changed but is not displayed.

2.2 Functions in the channel menu

The channel menu is reached from the main menu by pressing the key . Hit again  or  to return to the main menu.

2.2.1 Display

In the channel menu all parameters of the selected module are shown:

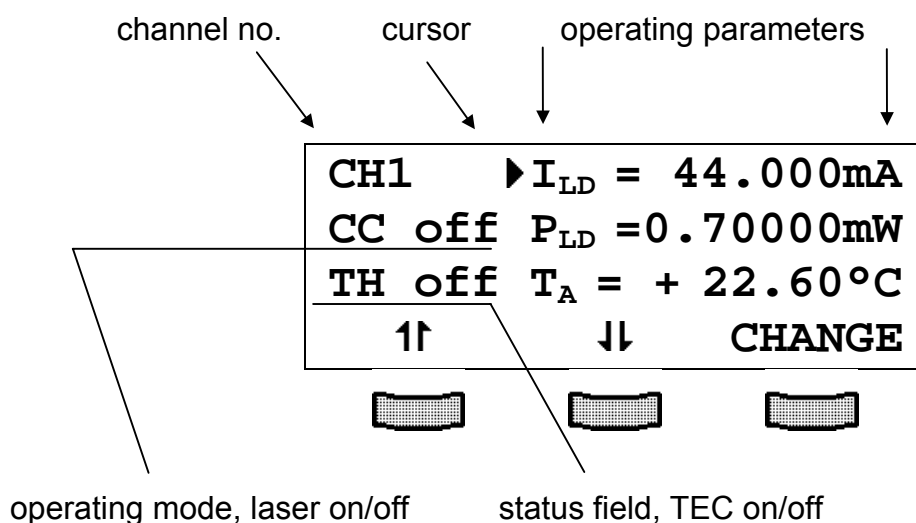

Only three parameters can be shown at a time, so there is a scroll function. All parameters are sorted in a virtual list, which can be run through with the cursor:

```

ILD = 44.000mA
PLD = 0.70000mW
TA = + 22.60°C
TS = + 15.00°C
↑
ULD = -1.86V
┌───────────────────┐
│ Imax = 50.00mA    │
│ ILIM = 55.6mA    │
│ IPD = 0.0500mA   │
└───────────────────┘
↓
C = 1.00000A/W
UBIA = 2.000 V
MODE = Iconst
LDPOL = AG
PDPOL = CG
  
```

$T_{WIN} = 0.461^{\circ}\text{C}$
 T_{WIN} off
TEC off
 $I_{TE} = 0.000\text{ A}$
 $U_{TE} = -0.48\text{ V}$
 $I_{TE\text{ LIM}} = 1.000\text{ A}$
Psh = 5.0 %
Ish = 15.0 %
Dsh = 10.0 %
Ishare ON
Thermistor
 $R_s = 10.000\text{ k}\Omega$
 $R_A = 40.959\text{ k}\Omega$
 $R_{WIN} = 0.200\text{ k}\Omega$
Exponential
 $R_0 = 10.000\text{ k}\Omega$
 $B = 3900.0\text{ k}\Omega$
 $T_0 = +25.00^{\circ}\text{C}$
 $C_1 = 1.0628\text{e-}3$
 $C_2 = 2.4277\text{e-}4$
 $C_3 = 7.0471\text{e-}8$

The operating mode field and the status field shows the actual status:

CC on/off	constant current mode
CP on/off	constant power mode
AD on/off	sensor is AD 590
TH on/off	sensor is thermistor
Open	TEC output switched on but too high-impedance
ILK	interlock open
OVL	laser diode output open
LIM	laser on but current has reached the limit value
WIN	TEC temperature out of activated temperature window

■**Vcc**■
■**fail**■ Internal Power failure, contact [Thorlabs](#)

■**OTP**■ over temperature

■**SENS**■ wrong or no sensor connected

2.2.2 Changing parameters

To set or change a numerical set parameter in the channel menu select the respective line with the cursor:

Example: I_{LD} is to change:

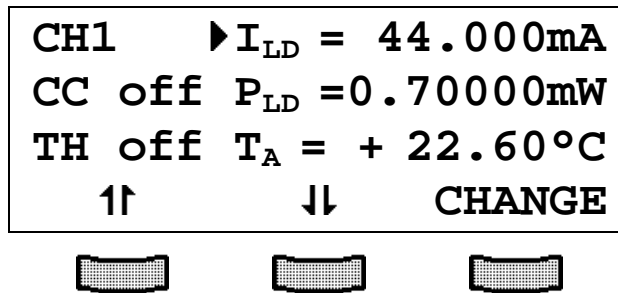

Pressing the softkey (**CHANGE**) activates the tuning knob and allows to change the selected parameter. If the selected parameter is a switch parameter (e.g. the polarity of the laser diode) the function of the softkeys changes:

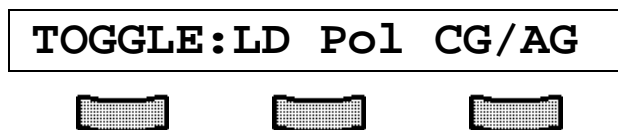

Press the right softkey to toggle the polarity.

Press  to terminate the procedure.

NOTE

Some parameters cannot be changed, as they are measurement values (i.e. the laser voltage) or may not be changed during the laser switched on. In this cases access is denied indicated by a long beep.

2.2.3 Selecting the polarity of the laser and the monitor diode

To change the polarity of the **laser diode** select the parameter

▶ **LDPOL =**

and select the desired polarity with **CHANGE** and toggle with **AG/CG**.

To change the polarity of the **monitor diode** select the parameter

▶ **PDPOL =**

and select the desired polarity with **CHANGE** and toggle with **AG/CG**.

2.2.4 Calibrating the monitor diode

To calibrate the monitor diode select the efficiency coefficient **C** of the monitor diode.

▶ **C = 0.2000A/W**

Press **CHANGE** to activate the tuning knob. Adjust the desired value and terminate the procedure with .

→ (Refer to chapter 2.2.2, "Changing parameters" on page 35)

The default value of η is 0.2000 A/W. It is valid without specific confirmation.

2.2.5 Selecting constant current or constant power mode

The current modules ITC8xxx offer two operating modes for the laser diode.

In constant current mode the laser diode current is kept constant. If the temperature of the laser changes the optical power will change too since the efficiency of the laser will change.

If the set-up uses a monitor diode receiving a certain part of the laser light the measured monitor diode current can be kept constant by adjusting the laser diode current correspondingly. Changes in temperature of the laser will cause a change of its efficiency but the laser diode current is re-set for the optical power to remain constant. This is called constant power mode, Pconst.

Select the parameter

► **MODE** =

and toggle between Pconst (CP) and Cconst (CC).

NOTE

For "constant power" mode a monitor diode is necessary in the set-up.

2.2.6 Selecting the type of the sensor

The sensor type can be chosen in the TED8xxx modules by selecting the line "Thermistor" respectively "AD590".

AD590 = AD590 and LM335 families

Thermistor = Thermistor. The corresponding range has to be selected

Select the desired type and press .

2.2.7 Calibrating the thermistor

2.2.7.1 Select the calculation method

If the relation between thermistor resistance and corresponding thermistor temperature is known all inputs and outputs can be calibrated in °C.

Two methods to calculate the resistance from temperature are implemented:

- The exponential method
- The Steinhart-Hart method

In the channel menu you can choose between those two methods and enter the corresponding parameters:

Select the line

Steinh.-Hart

resp.

Exponential

The right softkey toggles between the two methods.

Select the desired type and press  to make setting valid.

2.2.7.2 Exponential method

The dependency of resistance on temperature of an NTC-thermistor and vice versa is described by the formula:

$$R(T) = R^0 * e^{B_{val}(\frac{1}{T} - \frac{1}{T_0})} \Leftrightarrow T(R) = \frac{B_{val} * T_0}{T_0 * \ln(\frac{R}{R_0}) + B_{val}}$$

(temperatures in Kelvin)

with: R_0 : Thermistor nominal resistance at temperature T_0
 T_0 : Nominal temperature (typ. 298.15 K = 25°C)
 B_{val} : Energy constant

→ Refer to the data sheet of the thermistor.

To change the three parameters(R_0 , B , T_0) select them one by one and change them to the desired value.

Pressing  will make every setting valid.

2.2.7.3 Steinhart-Hart method

A further way to represent the relation between temperature and thermistor resistance is the method according to Steinhart-Hart

$$1/T = C1 + C2 * \ln(R) + C3 * (\ln(R))^3$$

with the three parameters C_1 , C_2 and C_3 .

To change the three parameters select them one by one and set them to the desired value.

Pressing  will terminate each input.

2.2.8 Setting a temperature window

A temperature window can be defined to operate laser diodes in a well defined temperature region. This function can be used especially with an external control computer. In local mode the “ERR” led will light up, if the temperature leaves the window.

To set the window select the parameter **Twin** and adjust the desired value.

Pressing  will make the new settings valid.

2.2.9 Activating the temperature protection

To activate or deactivate the temperature protection select the parameter:

▶ **Twin ON**

resp.

▶ **Twin OFF**

in the channel menu of the module.

2.2.10 Adjusting the bias voltage for the monitor diode

If required, the monitor diode may be driven with a bias voltage up to 10 V.

Attention

Before switching on bias voltage make sure that the photodiode polarity is set correctly (inverse direction).

If the photodiode is forward biased with a voltage, a current will flow through it that could damage or even destroy it.

The bias voltage can be set by adjusting the parameter:

▶ U_{BIA} =

in the channel menu of the module.

→ (Refer to chapter 2.2.2, "Changing parameters" on page 35)

2.2.11 Setting the P-, I- and D-share of the control loop

The temperature control behavior of the ITC8xxx can be adapted optimally to the individual laser set-up by optimizing the parameters P-, I- and D-share of the control loop.

They can be set separately in values from 0.1% to 100%:

Psh = P-share

Ish = I-share

Dsh = D-share

To change the three parameters select them one by one and set them to the desired value.

Press  to make the new value valid.

For adjustment of the parameters it is sometimes necessary to switch off the I-share completely. There is a separate switch parameter for this purpose:

Ishare = ON/OFF

You can toggle the function with the right softkey.

Press  to end the input.

2.3 Switching on and off

Modules can be switched on or off if the necessary parameters are set. For this purpose first select the module in the main menu.

Attention

Before switching on a combi module ITC8xxx first set the laser diode current I_{LIM} (hardware limit) for the applied laser diode with a screwdriver.

The corresponding potentiometer is marked I_{LIM} and is located at the front panel of the combi module.

→ (Refer to chapter 1.6.1, "Hardware limit I_{LIM} " starting on page 14)

Switching on the diode current I_{LD}

Pressing the key  will switch the module on or off not regarding the menu you are in as long as the module is selected (LED "SEL" lights). The LED "ON" of the respective module will light up with the module turned on.

The status display changes from:

CC off to: **CC on**

and in the main menu the set value changes to the actual value.

Due to a softstart function of the module, it takes about 1 second for the laser current to stabilize to the set value!

Switch on/off the TEC current in the channel menu

To switch on the TEC current select:

▶ **TEC OFF**

in the channel menu and toggle to:

▶ **TEC ON**

and vice versa.

The LED “ON” at the module will light up when switched on and the status display changes from:

TH off

to:

TH on

In the main menu the set value T_S changes to the actual value T_A .



CH1 ◀ 122.3mA 30.20°C

2.4 Error messages

Error messages are shown in the bottom line of the display.

If an error occurs, the display shows for example:

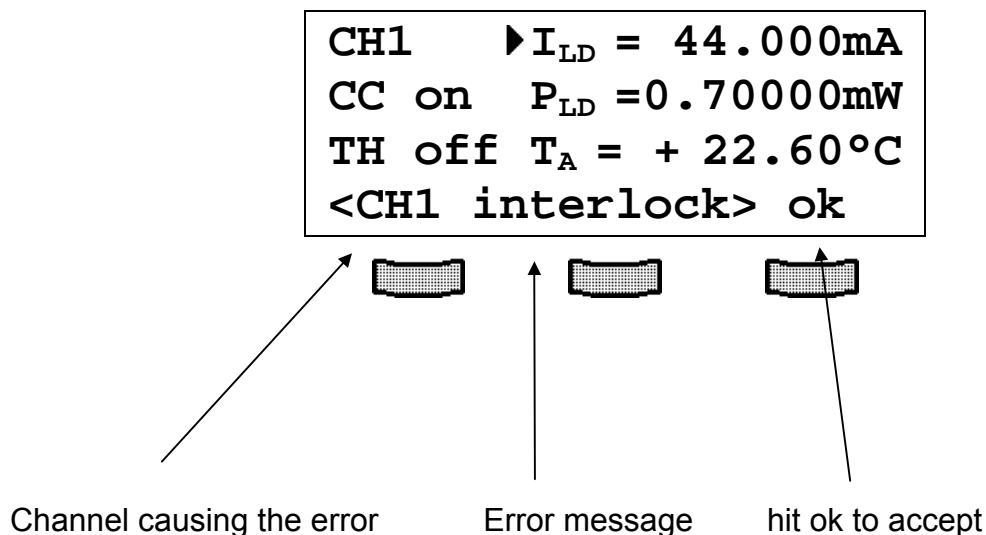

Possible error messages of a ITC8xxx module are:

Vcc fail	Internal supply voltage fails - module is damaged
OTP	Module is too hot. Operation is possible again after cooling down
ctrl Temp	Temperature is out of window
OPEN	Wiring to the laser has opened (danger!)
OPEN TEC	Wiring to TEC element has opened or TEC resistance to high
SENSOR	Wrong temperature sensor selected or not connected
INTERLOCK	Interlock line has opened / is open
Twin	Temperature is out of window (when window is activated)
NOT IF LD ON	It is not possible to change the parameters LDPOL , PDPOL , C , Twin when the laser diode is on
NOT IF TEC ON	It is not possible to change the calibration parameters of the thermistor, the calibration method or the sensor type when the TEC is on

If the error occurs during operation it is written in brackets:

<CH3 interlock>

If the error occurs when switching on or changing parameters it is written in cursor arrows:

▶CH3 interlock◀

If an error occurs, it has to be acknowledged by pressing the softkey "ok".
Until acknowledgement further operation is locked!.

3 Communication with a control computer

3.1 General notes on remote control

The description of the mainframe of the PRO8000 (-4) / PRO800 includes all instructions of how to prepare and execute the programming of the system via IEEE 488 computer interface.

Special operation features of a LDC8xxx current module are described here.

→ (Refer to chapter 2, "Operating the ITC8xxx" starting on page 29)

NOTE

All analog values are read and written in SI units, i.e. A (not mA), W (not mW) etc. Letters may be written in small or capital letters.

Attention

Before programming a current module first set the limit value of the laser diode current I_{LIM} (hardware limit) for the applied laser diode with a screwdriver.

The corresponding potentiometer is marked I_{LIM} and is situated at the front of the ITC8xxx module.

The value I_{LIM} is constantly measured by the PRO8000 (-4) / PRO800 and can be checked in the sub-menu of the ITC8xxx during setting.

→ (Refer to chapter 1.6.1, "Hardware limit I_{LIM} " on page 14)

3.1.1 Nomenclature

Program messages (PC \Rightarrow PRO8000 (-4)) are written in inverted commas:

"*IDN?"

Response messages (PRO8000 (-4) \Rightarrow PC) are written in brackets:

[:SLOT 1]

There is a decimal point:

1.234

Parameters are separated with comma:

"PLOT 2,0"

Commands are separated with semicolon:

"*IDN?;*STB?"

3.1.2 Data format

According to the IEEE 488.2 specifications all data variables are divided into 4 different data formats:

Character response data (<CRD>)

Is a single character or a string. Examples:

A or **ABGRS** or **A125TG** or **A1.23456A**

→ (Refer to IEE488.2 (8.7.1))

Numeric response data Type 1 (<NR1>)

Is a numerical value with sign in integer notation. Examples:

1 or **+1** or **-22** or **14356789432**

→ (Refer to IEE488.2 (8.7.2))

Numeric response data Type 2 (<NR2>)

Is a numerical value with or without sign in floating point notation without exponent.

Examples:

1.1 or +1.1 or -22.1 or 14356.789432

→ (Refer to IEE488.2 (8.7.3))

Numeric response data Type 3 (<NR3>)

Is a numerical value with or without sign in floating point notation with exponent with sign . Examples:

1.1E+1 or +1.1E-1 or -22.1E+1 or 143.56789432E+306

(Refer to IEE488.2 (8.7.4))

3.2 Commands

3.2.1 Select the module slot

" : SLOT <NR1> "	Selects a slot for further programming <Nr1>=1...8 (PRO8000), 1...2 (PRO800)
" : SLOT? "	Queries the selected slot [: SLOT <NR1><LF>]

3.2.2 Calibrating a photo diode (CALPD)

Programming:

" : CALPD : SET <NR3> "	Program the sensitivity calibration factor (η) of the monitor diode (A/W)
--------------------------------------	--

Reading:

" : CALPD : SET? "	Read the sensitivity (η) of the monitor diode [: CALPD : SET <NR3><LF>]
" : CALPD : MIN? "	Read the minimum sensitivity (η) of this module allowed [: CALPD : MIN <NR3><LF>]
" : CALPD : MAX? "	Read the maximum sensitivity (η) of this module allowed [: CALPD : MIN <NR3><LF>]

3.2.3 Thermistor calibration (exponential method)

Programming:

":CALTB:SET <NR3>"	Programming the energy constant B_{val}
":CALTR:SET <NR3>"	Programming the nominal resistance R_0
":CALTT:SET <NR3>"	Programming the nominal temperature T_0

Reading:

":CALTB:SET?"	Reading the energy constant B_{val} [:CALTB:SET <NR3><LF>]
":CALTR:SET?"	Reading the nominal resistance R_0 [:CALTR:SET <NR3><LF>]
":CALTT:SET?"	Reading the nominal temperature T_0 [:CALTT:SET <NR3><LF>]
":CALTB:MIN?"	Reading the minimum B_{val} allowed [:CALTB:MIN <NR3><LF>]
":CALTR:MIN?"	Reading the minimum R_0 allowed [:CALTR:MIN <NR3><LF>]
":CALTT:MIN?"	Reading the minimum T_0 allowed [:CALTT:MIN <NR3><LF>]
":CALTB:MAX?"	Reading the maximum B_{val} allowed [:CALTB:MAX <NR3><LF>]
":CALTR:MAX?"	Reading the maximum R_0 allowed [:CALTR:MAX <NR3><LF>]
":CALTT:MAX?"	Reading the maximum T_0 allowed [:CALTT:MAX <NR3><LF>]

(Refer to chapter 2.2.7.2, "Exponential method" on page 39)

NOTE

The selection on how the sensor calibration is done (exponential method or Steinhart-Hart method) is done by the order in which you transmit the coefficients.

If the last transmitted calibration command belongs to the exponential method (see above), then the calculation is also done with the exponential method.

If the last command was a Steinhart-Hart parameter, then this method is chosen.

3.2.4 Thermistor calibration (Steinhart-Hart method)

Programming:

" :CALTC1:SET <NR3> " Set the Steinhart-Hart coefficient C1
" :CALTC2:SET <NR3> " Set the Steinhart-Hart coefficient C2
" :CALTC3:SET <NR3> " Set the Steinhart-Hart coefficient C3

Reading:

" :CALTC1:SET? " Read the Steinhart-Hart coefficient C1
[:CALTC1:SET <NR3><LF>]
" :CALTC2:SET? " Read the Steinhart-Hart coefficient C2
[:CALTC2:SET <NR3><LF>]
" :CALTC3:SET? " Read the Steinhart-Hart coefficient C3
[:CALTC3:SET <NR3><LF>]
" :CALTC1:MIN? " Read the minimum C1 allowed
[:CALTC1:MIN <NR3><LF>]
" :CALTC2:MIN? " Read the minimum C2 allowed
[:CALTC2:MIN <NR3><LF>]
" :CALTC3:MIN? " Read the minimum C3 allowed
[:CALTC3:MIN <NR3><LF>]
" :CALTC1:MAX? " Read the maximum C1 allowed
[:CALTC1:MAX <NR3><LF>]
" :CALTC2:MAX? " Read the maximum C2 allowed
[:CALTC2:MAX <NR3><LF>]
" :CALTC3:MAX? " Read the maximum C3 allowed
[:CALTC3:MAX <NR3><LF>]

- ➔ (Refer to chapter 2.2.7.3, "Steinhart-Hart method" on page 40)
- ➔ For selection between both methods, see the note on the previous page!

3.2.5 Programming the laser diode current (ILD)

Programming:

" : ILD : SET <NR3> "	Program the laser diode set current
" : ILD : START <NR3> "	Program the laser diode start current for "ELCH" ¹
" : ILD : STOP <NR3> "	Program the laser diode stop current for "ELCH"
" : ILD : MEAS <NR1> "	Program the laser diode current as measurement value on position <NR1> in the output string for "ELCH" (<NR1> = 1...8)

Reading:

" : ILD : SET? "	Read the laser diode set current [: ILD : SET <NR3><LF>]
" : ILD : ACT? "	Read the actual laser diode current [: ILD : ACT <NR3><LF>]
" : ILD : MIN? "	Read the minimum laser diode current allowed [: ILD : MIN <NR3><LF>]
" : ILD : MAX? "	Read the maximum laser diode current allowed [: ILD : MAX <NR3><LF>]
" : ILD : MIN_W? "	Read the minimum laser diode current for Ild -DAC = 0000 [: ILD : MIN_W <NR3><LF>]
" : ILD : MAX_W? "	Read the maximum laser diode current for Ild -DAC = FFFF [: ILD : MAX_W <NR3><LF>]
" : ILD : MIN_R? "	Read the minimum laser diode current for Ild -ADC = 0000 [: ILD : MIN_R <NR3><LF>]
" : ILD : MAX_R? "	Read the maximum laser diode current for Ild -ADC = FFFF [: ILD : MAX_R <NR3><LF>]

¹ "ELCH": Electrical CHaracterization

" : ILD : START ? "	Read the laser diode start current for "ELCH" [: ILD : START <NR3><LF>]
" : ILD : STOP ? "	Read the laser diode stop current for "ELCH" [: ILD : STOP <NR3><LF>]
" : ILD : MEAS ? "	Read the position of the laser diode current as measurement value in the output string for "ELCH" (1...8, 0 if not selected) [: ILD : MEAS <NR1><LF>]

3.2.6 Programming the monitor diode current (IMD)

Programming:

" : IMD : SET <NR3> "	Program the monitor diode set current
" : IMD : START <NR3> "	Program the monitor diode start current for "ELCH"
" : IMD : STOP <NR3> "	Program the monitor diode stop current for "ELCH"
" : IMD : MEAS <NR1> "	Program the monitor diode current to be measurement value in the "ELCH" output string on position <NR1> (1...8)

Reading:

" : IMD : SET? "	Read the monitor diode set current [: IMD : SET <NR3><LF>]
" : IMD : ACT? "	Read the actual monitor diode current [: IMD : ACT <NR3><LF>]
" : IMD : MIN? "	Read minimum monitor diode set current allowed [: IMD : MIN <NR3><LF>]
" : IMD : MAX? "	Read maximum monitor diode set current allowed [: IMD : MAX <NR3><LF>]
" : IMD : MIN_W? "	Read minimum monitor diode current for I _{pd} – DAC = 0000 [: IMD : MIN_W <NR3><LF>]
" : IMD : MAX_W? "	Read maximum monitor diode current for I _{pd} – DAC = FFFF [: IMD : MAX_W <NR3><LF>]
" : IMD : MIN_R? "	Read minimum monitor diode current for I _{pd} – ADC = 0000 [: IMD : MIN_R <NR3><LF>]
" : IMD : MAX_R? "	Read maximum monitor diode current for I _{pd} – ADC = FFFF [: IMD : MAX_R <NR3><LF>]

" : IMD : START ? "	Read the monitor diode start current for "ELCH" [: IMD : START <NR3><LF>]
" : IMD : STOP ? "	Read the monitor diode stop current for "ELCH" [: IMD : STOP <NR3><LF>]
" : IMD : MEAS ? "	Read the position of the monitor diode current as measurement value in the "ELCH" output string (1...8, 0 if not selected) [: IMD : MEAS <NR1><LF>]

3.2.7 Switching the I-share on and off (INTEG)

Programming:

" :INTEG ON" Switch the I-share on
 " :INTEG OFF" Switch the I-share off

Reading:

" :INTEG?" Read status of the I-share
 [:INTEG ON<LF>]
 [:INTEG OFF<LF>]

3.2.8 Reading the TEC current (ITE)

Programming

" :ITE:MEAS <NR1>" Program the TEC current as measurement value on position <NR1> in the output string for "ELCH" (<NR1> = 1...8)

Reading:

" :ITE:ACT?" Read the actual TEC (or heater) current
 [:ITE:ACT <NR3><LF>]
 " :ITE:MIN_R?" Read the minimum TEC current for
 Ite –ADC = 0000
 [:ITE:MIN_R <NR3><LF>]
 " :ITE:MAX_R?" Read the maximum TEC current for
 Ite –ADC = FFFF
 [:ITE:MAX_R <NR3><LF>]
 " :ITE:MEAS?" Read the position of the TEC current as measurement value in the "ELCH" output string (1...8, 0 if not selected)
 [:ITE:MEAS <NR1><LF>]

3.2.9 Switching the laser output on and off (LASER)

Programming:

" :LASER ON"	Switch the laser output on
" :LASER OFF"	Switch the laser output off

Reading:

" :LASER? "	Read status of the laser output
	[:LASER ON<LF>]
	[:LASER OFF<LF>]

3.2.10 Selecting the laser diode polarity (LDPOL)

Programming:

" :LDPOL AG"	Select anode on ground
" :LDPOL CG"	Select cathode on ground

Reading:

" :LDPOL? "	Read the laser diode polarity
	[:LDPOL AG<LF>]
	[:LDPOL CG<LF>]

3.2.11 Programming the laser diode software-limit (LIMC)

Programming:

" :LIMC:SET <NR3>" Program the laser diode current limit

Reading:

" :LIMC:SET?" Read the laser diode current limit
 [:LIMC:SET <NR3><LF>]

" :LIMC:MIN?" Read the minimum possible laser diode current limit
 [:LIMC:MIN <NR3><LF>]

" :LIMC:MAX?" Read the maximum possible laser diode current limit
 [:LIMC:MAX <NR3><LF>]

" :LIMC:MIN_W?" Read the laser diode current limit for
 Ilim – DAC = 0000
 [:LIMC:MIN_W <NR3><LF>]

" :LIMC:MAX_W?" Read the laser diode current limit for
 Ilim – DAC = FFFF
 [:LIMC:MAX_W <NR3><LF>]

→ (Refer to Chapter 1.6.2, "Software limits I_{MAX} and $I_{TE\ LIM}$ " on page 15)

3.2.12 Reading the laser diode hardware-limit (LIMCP)

Reading:

" :LIMCP:ACT? "	Read the actual hardware-limit [:LIMCP:ACT <NR3><LF>]
" :LIMCP:MIN_R? "	Read I _{max} – ADC = 0000 [:LIMCP:MIN_R <NR3><LF>]
" :LIMCP:MAX_R? "	Read I _{max} – ADC = FFFF [:LIMCP:MAX_R <NR3><LF>]

→ (Refer to Chapter 1.6.1, "Hardware limit I_{LIM}" starting on page 14)

3.2.13 Programming the TEC current software-limit (LIMT)

Programming:

" :LIMT:SET <NR3> "	Program the TEC software current -limit
---------------------	---

Reading:

" :LIMT:SET? "	Read the TEC current software-limit [:LIMT:SET <NR3><LF>]
" :LIMT:MIN? "	Read the minimum TEC software current -limit allowed [:LIMT:MIN <NR3><LF>]
" :LIMT:MAX? "	Read the maximum TEC software current -limit allowed [:LIMT:MAX <NR3><LF>]
" :LIMT:MIN_W? "	Read I _{TE LIM} - ADC = 0000 [:LIMT:MIN_W <NR3><LF>]
" :LIMT:MAX_W? "	Read I _{TE LIM} - ADC = FFFF [:LIMT:MAX_W <NR3><LF>]

→ (Refer to Chapter 1.6.2, "Software limits I_{MAX} and I_{TE LIM}" on page 15)

3.2.14 Selecting the mode of operation (MODE)

Programming:

" :MODE CC" Constant current mode
" :MODE CP" Constant power mode

Reading:

" :MODE? " Read the mode of operation
 [:MODE CC<LF>]
 [:MODE CP<LF>]

3.2.15 Selecting the photo diode polarity (PDPOL)

Programming:

" :PDPOL AG" Select anode on ground
" :PDPOL CG" Select cathode on ground

Reading:

" :PDPOL? " Read the monitor diode polarity
 [:PDPOL AG<LF>]
 [:PDPOL CG<LF>]

3.2.16 Programming the optical power (POPT)

Programming:

" : POPT : SET <NR3> " Program the optical power

Reading:

" : POPT : SET? " Read the set optical power
[: POPT : SET <NR3><LF>]

" : POPT : ACT? " Read the actual optical power
[: POPT : ACT <NR3><LF>]

" : POPT : MIN? " Read the minimum set optical power allowed
[: POPT : MIN <NR3><LF>]

" : POPT : MAX? " Read the maximum set optical power allowed
[: POPT : MAX <NR3><LF>]

" : POPT : MIN_W? " Read the optical power for $P_{LD} - DAC = 0000$
[: POPT : MIN_W <NR3><LF>]

" : POPT : MAX_W? " Read the optical power for $P_{LD} - DAC = FFFF$
[: POPT : MAX_W <NR3><LF>]

" : POPT : MIN_R? " Read the optical power for $P_{LD} - ADC = 0000$
[: POPT : MIN_R <NR3><LF>]

" : POPT : MAX_R? " Read the optical power for $P_{LD} - ADC = FFFF$
[: POPT : MAX_R <NR3><LF>]

3.2.17 Programming the resistance of the thermistor (RESI)

Programming:

":RESI:SET <NR3>"	Program the resistance of the temperature sensor (thermistor)
":RESI:MEAS <NR1>"	RESI as measurement value for "ELCH" on string position <NR1> (1....8)

Reading:

":RESI:SET?"	Read the set resistance of the sensor (thermistor, [:RESI:SET <NR3><LF>]
":RESI:ACT?"	Read the actual resistance of the sensor [:RESI:ACT <NR3><LF>]
":RESI:MIN?"	Read the minimum set resistance of the sensor allowed [:RESI:MIN <NR3><LF>]
":RESI:MAX?"	Read the maximum set resistance of the sensor allowed [:RESI:MAX <NR3><LF>]
":RESI:MIN_W?"	Read R - DAC = 0000 [:RESI:MIN_W <NR3><LF>]
":RESI:MAX_W?"	Read R - DAC = FFFF [:RESI:MAX_W <NR3><LF>]
":RESI:MIN_R?"	Read R - ADC = 0000 [:RESI:MIN_R <NR3><LF>]
":RESI:MAX_R?"	Read R - ADC = FFFF [:RESI:MAX_R <NR3><LF>]
":RESI:MEAS?"	Read string position of R (1....8) for "ELCH" as measurement value [:RESI:MEAS <NR1><LF>]

3.2.18 Programming the resistance window (RWIN)

Programming:

" :RWIN:SET <NR3> " Set the resistance window

Reading:

" :RWIN:SET? " Read the set resistance window
[:RWIN:SET <NR3><LF>]

" :RWIN:MIN? " Read the minimum set resistance window allowed
[:RWIN:MIN <NR3><LF>]

" :RWIN:MAX? " Read the maximum set resistance window allowed
[:RWIN:MAX <NR3><LF>]

" :RWIN:MIN_W? " Read Rwin - DAC = 0000
[:RWIN:MIN_W <NR3><LF>]

" :RWIN:MAX_W? " Read Rwin - DAC = FFFF
[:RWIN:MAX_W <NR3><LF>]

3.2.19 Selecting the sensor (SENS)

Programming:

" :SENS AD " Sensor is AD590 family

" :SENS TH " Sensor is thermistor

Reading:

" :SENS? " Read the actual sensor type
[:SENS AD<LF>]
[:SENS TH<LF>]

3.2.20 Programming the PID shares (SHAREP, -I, -D)

Programming:

```
" : SHAREP : SET <NR3> "   Program the P-share
" : SHAREI : SET <NR3> "   Program the I-share
" : SHARED : SET <NR3> "   Program the D-share
```

Reading:

```
" : SHAREP : SET? "         Read the P-share
                             [ : SHAREP : SET <NR3><LF> ]
" : SHAREI : SET? "         Read the I-share
                             [ : SHAREI : SET <NR3><LF> ]
" : SHARED : SET? "         Read the D-share
                             [ : SHARED : SET <NR3><LF> ]
" : SHAREP : MIN? "         Read the minimum P-share allowed
                             [ : SHAREP : MIN <NR3><LF> ]
" : SHAREI : MIN? "         Read the minimum I-share allowed
                             [ : SHAREI : MIN <NR3><LF> ]
" : SHARED : MIN? "         Read the minimum D-share allowed
                             [ : SHARED : MIN <NR3><LF> ]
" : SHAREP : MAX? "         Read the maximum P-share allowed
                             [ : SHAREP : MAX <NR3><LF> ]
" : SHAREI : MAX? "         Read the maximum I-share allowed
                             [ : SHAREI : MAX <NR3><LF> ]
" : SHARED : MAX? "         Read the maximum D-share allowed
                             [ : SHARED : MAX <NR3><LF> ]
```

→ (Refer to chapter 1.8.2, "PID adjustment" on page 27)

3.2.21 Switching the TEC on and off (TEC)

Programming:

" :TEC ON"	Switch the TEC output on
" :TEC OFF"	Switch the TEC output off

Reading:

" :TEC?"	Read status of the output
	[:TEC ON<LF>]
	[:TEC OFF<LF>]

3.2.22 Programming the temperature (TEMP)

Programming:

":TEMP:SET <NR3>" Program the temperature
":TEMP:MEAS <NR1>" Program temperature to be measurement value for "ELCH" on string position <NR1> (1....8)

Reading:

":TEMP:SET?" Read the set temperature
[:TEMP:SET <NR3><LF>]

":TEMP:ACT?" Read the actual temperature
[:TEMP:ACT <NR3><LF>]

":TEMP:MIN?" Read the minimum set temperature allowed
[:TEMP:MIN <NR3><LF>]

":TEMP:MAX?" Read the maximum set temperature allowed
[:TEMP:MAX <NR3><LF>]

":TEMP:MIN_W?" Read T - DAC = 0000
[:TEMP:MIN_W <NR3><LF>]

":TEMP:MAX_W?" Read T - DAC = FFFF
[:TEMP:MAX_W <NR3><LF>]

":TEMP:MIN_R?" Read T - ADC = 0000
[:TEMP:MIN_R <NR3><LF>]

":TEMP:MAX_R?" Read T - ADC = FFFF
[:TEMP:MAX_R <NR3><LF>]

":TEMP:MEAS?" Read string position (1....8) of temperature as measurement value for "ELCH".
[:TEMP:MEAS <NR1><LF>]

3.2.23 Switching the temperature protection on and off (TP)

Programming:

" : TP ON "	Switch temperature protection on
" : TP OFF "	Switch temperature protection off

Reading:

" : TP ? "	Read status of the temperature protection
	[: TP ON <LF>]
	[: TP OFF <LF>]

3.2.24 Programming the temperature window (TWIN)

Programming:

" :TWIN:SET <NR3> " Program the temperature window

Reading:

" :TWIN:SET? " Read the set temperature window

[:TWIN:SET <NR3><LF>]

" :TWIN:MIN? " Read the minimum set temperature window allowed

[:TWIN:MIN <NR3><LF>]

" :TWIN:MAX? " Read the maximum set temperature window allowed

[:TWIN:MAX <NR3><LF>]

" :TWIN:MIN_W? " Read Twin - DAC = 0000

[:TWIN:MIN_W <NR3><LF>]

" :TWIN:MAX_W? " Read Twin - DAC = FFFF

[:TWIN:MAX_W <NR3><LF>]

3.2.25 Read Type of module (TYPE)

"TYPE ID? " Read module identification (here 159)

[:TYPE 159<LF>]

3.2.26 Programming the bias voltage (VBIAS)

Programming:

":VBIAS:SET <NR3>" Program the bias voltage
":VBIAS:START <NR3>" Program the bias start voltage for "ELCH"
":VBIAS:STOP <NR3>" Program the bias stop voltage for "ELCH"

Reading:

":VBIAS:SET?" Read the bias voltage
[**":VBIAS:SET <NR3><LF>"**]
":VBIAS:MIN?" Read the minimum bias voltage allowed
[**":VBIAS:MIN <NR3><LF>"**]
":VBIAS:MAX?" Read the maximum bias voltage allowed
[**":VBIAS:MAX <NR3><LF>"**]
":VBIAS:MIN_W?" Read $U_{BIAS} - DAC = 0000$
[**":VBIAS:MIN_W <NR3><LF>"**]
":VBIAS:MAX_W?" Read $U_{BIAS} - DAC = FFFF$
[**":VBIAS:MAX_W <NR3><LF>"**]
":VBIAS:START?" Read the bias start voltage for "ELCH"
[**":VBIAS:START <NR3><LF>"**]
":VBIAS:STOP?" Read the bias stop voltage for "ELCH"
[**":VBIAS:STOP <NR3><LF>"**]

3.2.27 Reading the laser diode voltage (VLD)

Programming:

" :VLD:MEAS <NR1> " Program Vld to be a measurement value for "ELCH" on position <NR1> (1....8) in the output string.

Reading:

" :VLD:ACT? " Read the actual laser voltage
[:VLD:ACT <NR3><LF>]

" :VLD:MIN_R? " Read Uld – ADC = 0000
[:VLD:MIN_R <NR3><LF>]

" :VLD:MAX_R? " Read Uld – ADC = FFFF
[:VLD:MAX_R <NR3><LF>]

" :VLD:MEAS? " Read the position of Vld in the "ELCH" output string (1....8, 0 if not selected)
[:VLD:MEAS <NR1><LF>]

3.2.28 Reading the TEC voltage (VTE)

Reading:

":VTE:MEAS <NR1>" Select TEC voltage to be measurement value for "ELCH" on string position <NR1> (1....8)

Reading:

":VTE:ACT?" Read the actual TEC voltage
[:VTE:ACT <NR3><LF>]

":VTE:MIN_R?" Read $U_{TE} - ADC = 0000$
[:VTE:MIN_R <NR3><LF>]

":VTE:MAX_R?" Read $U_{TE} - ADC = FFFF$
[:VTE:MAX_R <NR3><LF>]

":VTE:MEAS?" Read string position (1....8) of peltier voltage as measurement value for "ELCH" .
[:VTE:MEAS <NR1><LF>]

3.3 1301 ... 1316 error messages of the ITC8xxx

[1301,"Interlock is open"]

Possible reason: Interlock line open.

→ (Refer to chapter 1.7.3, "Connecting interlock and status " on page 20)

[1302,"Open circuit"]

Possible reason: Cable to the laser diode has opened. Compliance voltage not high enough.

[1303,"Over temperature"]

Possible reason: Module temperature too high. Switch off the output and wait until the module has cooled down. Maintain proper air flow.

[1304,"Internal power failure"]

Possible reason: Severe hardware error. Contact [Thorlabs](#).

[1305,"No calibrating of sensor during TEC on"]

Possible reason: The sensor cannot be calibrated with the TEC output on.

[1306,"No calibrating of PD during laser on in constant power mode"]

Possible reason: The monitor diode cannot be calibrated in constant power mode with laser output on.

[1307,"No setting of ILD during constant power mode"]

Possible reason: The set value of the laser diode current cannot be changed in constant power mode.

[1308,"No setting of IMD in constant current mode"]

Possible reason: The set value of the monitor diode current and the laser power cannot be changed in constant current mode.

[1309,"No LD polarity change during laser on"]

Possible reason: The polarity of the laser diode cannot be changed with the laser output on.

[1310,"No PD polarity change during laser on"]

Possible reason: The polarity of the monitor diode cannot be changed with the laser output on.

[1311,"No mode change during laser on"]

Possible reason: The operating mode CC or CP cannot be changed with the laser output on.

[1312,"Wrong or no sensor"]

Possible reason: Wrong or no sensor connected. Wrong sensor selected.

[1313,"Wrong command for this sensor"]

Possible reason: The used command is not allowed for the selected sensor.
(Example :RWIN with an AD590)

[1314,"No sensor change during TEC on allowed"]

Possible reason: The sensor type cannot be changed if the TEC output is switched on.

[1315,"Attempt to switch on laser while temperature is out of window"]

Possible reason: The actual temperature T_{ACT} is smaller than $T_{SET} - T_{WIN}$ or bigger than $T_{SET} + T_{WIN}$.

[1316,"Attempt to activate Twin during laser on"]

Possible reason: The temperature window cannot be activated with the laser output on.

3.4 Status reporting

The ITC8xxxx modules provide three 16 bit registers DEC, DEE and EDE (see Figure 11) together with four 8 bit registers ESR, STB, ESE and SRE (see Figure 12) of the mainframe to program various service request functions and status reporting.

➔ (Please refer to the IEEE488.2-1992 standard chapter 11)

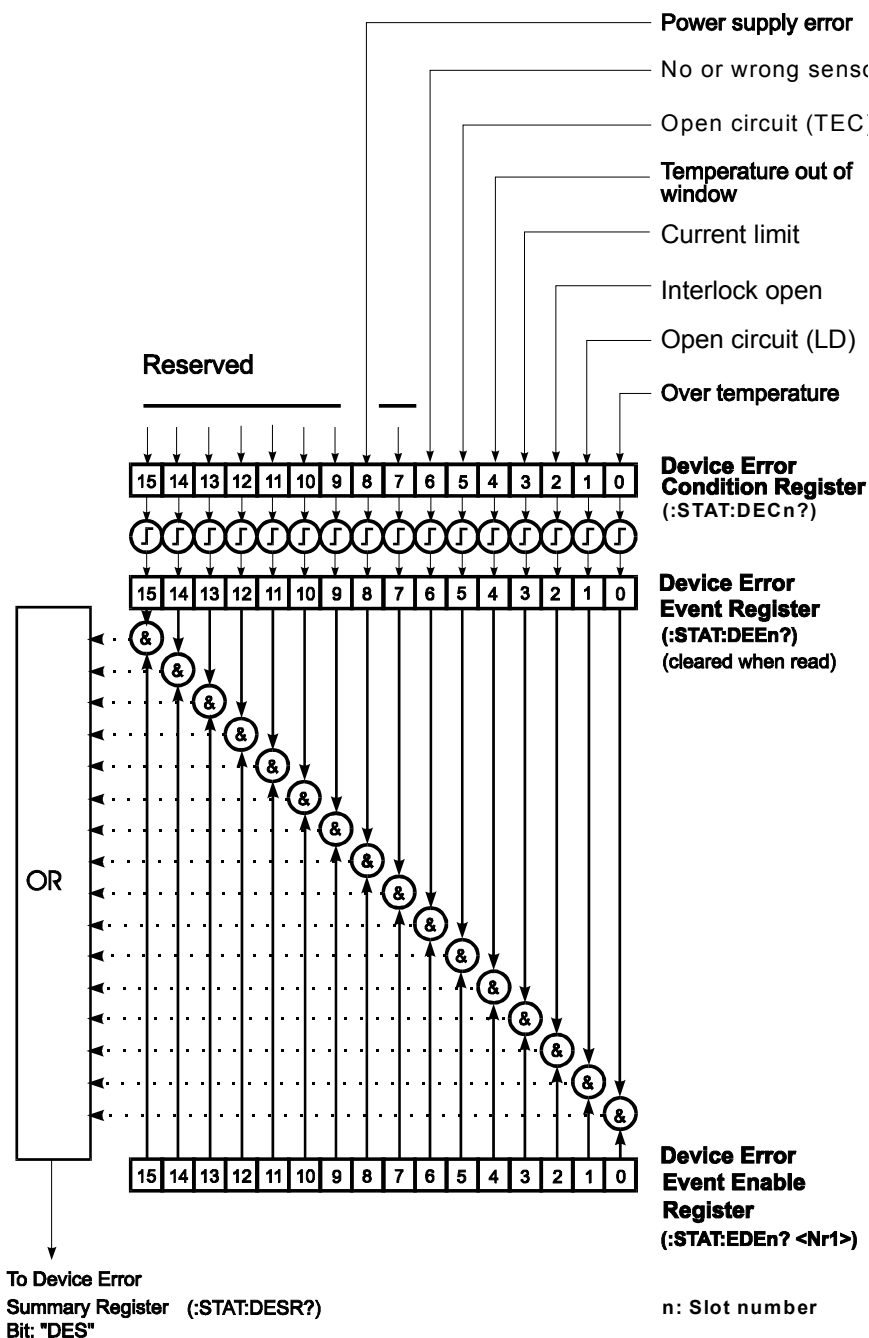

Figure 11 The ITC8xxx device error registers DEC, DEE and EDE

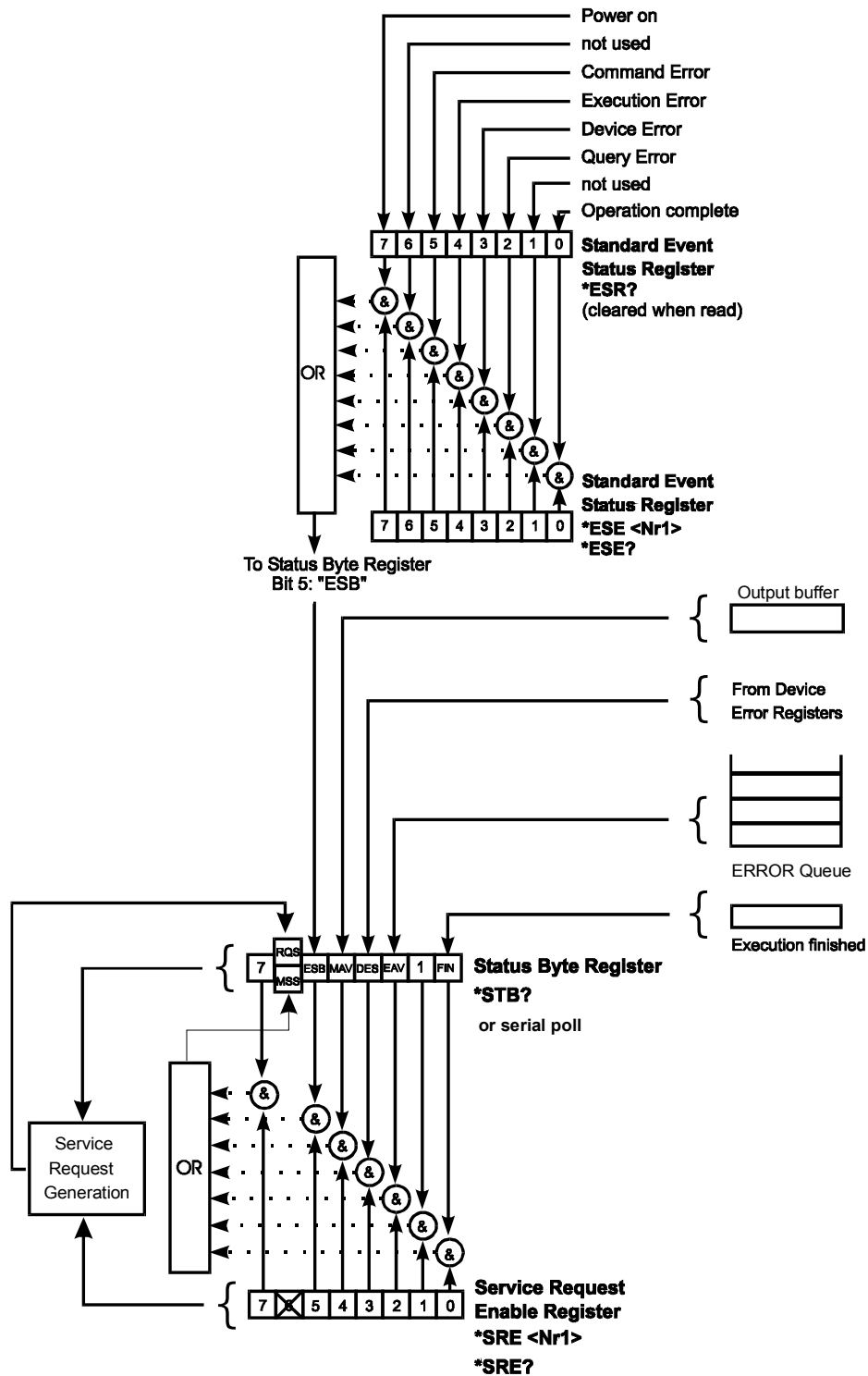

Figure 12 The PRO8000 (-4) / PRO800 register ESR, ESE, STB and SRE

3.4.1 Standard event status register (ESR)

The bits of this register represent the following standard events:

Power on	This event bit indicates, that an off to on transition has occurred in the power supply. So it is high after turning on the device for the first time.
User request	(Not used)
Command error	A command error occurred.
Execution error	An execution error occurred.
Device dependent error	A device dependent error occurred.
Query error	A query error occurred.
Request control	(Not used)
Operation complete	Can be set with " *OPC ".

The ESR can be read directly with the command "***ESR?**". This read command clears the ESR. The content of the ESR cannot be set.

The bits are active high.

3.4.2 Standard event status enable register (ESE)

The bits of the ESE are used to select, which bits of the ESR shall influence bit 5 (ESB) of the STB. The 8 bits of the ESE are combined with the according 8 bits of the ESR via a wired "AND"-function. These 8 results are combined with a logical "OR"-function, so that any "hit" leads to a logical 1 in bit 5 (ESB) of the STB. As any bit of the STB can assert an SRQ, every event (bit of the ESR) can be used to assert an SRQ.

3.4.3 Status byte register (STB)

The bits of this register are showing the status of the PRO8000 (-4) / PRO800.

RQS	RQS: Request service message: Shows, that this device has asserted SRQ (read via serial poll).
MSS	Master summary status: Shows that this device requests a service (read via " *STB? ").
MAV	(Message AVailable) This bit is high after a query request, as a result "waits" in the output queue to be fetched. It is low, if the output queue is empty.
DES	(Device Error Status) This bit is high after a device error occurred. Which device errors will set this bit is defined with the EDE.
EAV	(Error AVailable) This bit is high as long as there are errors in the error queue.
FIN	(command FINished) This bit is high, after a command has finished and all bits of the STB have been set.

The STB can be read directly with the command "***STB?**". The content of the STB cannot be set. The bits are active high.

All bits except bit 6 of the STB can be used to assert a service request (SRQ)

→ (Please refer to 3.4.5). Alternatively the SRQ can be recognized using the command "***STB?**" (Please refer to 3.4.6) or by serial poll (Please refer to 3.4.7).

3.4.4 Service request enable register (SRE)

The bits of the SRE are used to select, which bits of the STB shall assert an SRQ.

Bit 0, 1, 2, 3, 4, 5 and 7 of the STB are related to the according 7 bits of the SRE by logical "AND". These 7 results are combined by a logical "OR", so that any "hit" leads to a logical 1 in bit 6 of the STB and asserts an SRQ.

3.4.5 Reading the STB by detecting SRQ

If an SRQ is asserted (see 3.4.4) bit 6 of the STB is set to logical 1, so that the controller can detect which device asserted the SRQ by auto serial polling.

3.4.6 Reading the STB by "`*STB?`" command

If the controller does not "listen" to SRQ's at all, the service request can be detected by reading the status byte with the command "`*STB?`".

If bit 6 is logical 1, a service request was asserted.

3.4.7 Reading the STB by serial poll

If the controller does not support auto serial poll, the service request can also be detected via manual serial poll.

If bit 6 is logical 1, a service request was asserted.

3.4.8 Device error condition register (DEC)

The bits of this register show the errors, that occur during operation (operation errors). The bits are active high.

If the error disappears, the bits are reset to low.

For the ITC8xxx combi controller modules bits 0 to 6 and 8 are used:

(0) Over temperature	Temperature too high. Wait until the module has cooled down. Maintain proper air flow.
(1) Open circuit (LD)	Laser diode circuit is open
(2) Interlock open	The interlock has opened or path resistance is $>430 \Omega$.
(3) Current limit	The current limit is reached and the protection circuit is active now. Noise and drift specs are not valid any more.
(4) Temperature out of window	TEC temperature is out of specified window.
(5) Open circuit (TEC)	TEC circuit is open.
(6) No or wrong sensor	Temperature sensor not connected or wrong type.
(8) Power supply error	Internal power supply error.

The DEC can be read but not set. Reading does not clear the DEC.

3.4.9 Device error event register (DEE)

The bits of this register hold the errors, that occurred during operation (operation errors). So each bit of the DEC sets the according bit of the DEE.

The DEE can be read but not set. Reading clears the DEE.

3.4.10 Device error event enable register (EDE)

The bits of the EDE are used to select, which bits of the DEE shall influence bit 3 (DES) of the STB. The 8 bits of the EDE are related by logical "AND" to the according 8 bits of the DEE. These 8 results are combined by logical "OR", so that any "hit" leads to a logical 1 in bit 3 (DES) of the STB. As any bit of the STB can assert an SRQ, every error (bit of the DEE) can be used to assert an SRQ.

4 Service and Maintenance

4.1 General remarks

The ITC8xxx modules do not need any maintenance by the user.

If highest precision of measurements is vital to you, you should have recalibrated the ITC8xxx module about every two years.

4.2 Troubleshooting

In case that your PRO8000 / PRO800 system shows malfunction please check the following items:

◆ Module does not work at all (no display on the mainframe):

- Mainframe PRO8000 (-4) / PRO800 connected properly to the mains?
 - Connect the PRO8000 (-4) / PRO800 to the power line, take care of the right voltage setting of your mainframe.
 - Mainframe PRO8000 (-4) / PRO800 turned on?
 - Turn on your PRO8000 (-4) / PRO800 with the key mains-switch.
 - Control the fuse at the rear panel of the PRO8000 (-4) / PRO800 mainframe.
 - If blown up, replace the fuse by the correct type
- ➔ (refer to your PRO8000 (-4) / PRO800 mainframe operating manual to select the appropriate fuse)

◆ The PRO8000 (-4) / PRO800 display works, but not the module:

- Is the module inserted correctly and are all mounting screws tightened?
 - Insert the module in the desired slot and tighten all mounting screws properly.

◆ You don't get the desired laser output power

- Is the interlock closed?
 - Control the resistance between the interlock pins of the connector jack not to be more than 430 Ω .
(refer to section 1.7.3, "Connecting interlock and status " on page 20)

- Do you have selected the desired module for input?
 - (The LED "SEL" on the front panel of the module must be on)
Select the desired module on the display by means of the up- and down arrow keys.

- Do you have turned on the laser output in the main menu or one of the sub-menus?
 - Select the desired module on the display by means of the up- and down arrow keys
 - Change the status setting from "off" to "on".
- ➔ The LED "ON" on the front panel of the module must be on

- Are the hard- and/or software limits I_{LIM} and I_{MAX} set to 0?
 - Adjust the hardware limit I_{LIM} by means of the potentiometer on the ITC8xxx front panel and the software limit I_{MAX} in the channel menu to appropriate values.

- Is the output power set to 0?
 - Adjust the output power in the channel menu or with the command
" :POPT:SET <NR3> "

- Is the laser diode installed properly?
 - Control the connection cable.

- Is the laser diode poled correctly?
 - If not, change the polarity with the "**:LDPOL**" command or in the channel menu.

- Is the photo diode connected properly?
 - Check the connecting cable.

- Is the photo diode poled correctly?
 - If not, change the polarity with the "**:PDPOL**" command or in the channel menu.

- Do you use a bias voltage with the photo diode in photocurrent mode?
 - Turn off bias voltage in the channel menu, with the "**:PDBIA OFF**" command or change the polarity of the diode for photo element mode.

- Is the correct photo diode efficiency set (A/W)?
 - Enter the coefficient in the channel menu or with the command "**:CALPD:SET**"

- Do you have turned on the temperature controller in the main menu or one of the sub-menus?
 - Change the status setting from "off" to "on".
- ➔ The LED "ON" on the front panel of the module must be on

◆ You don't get the desired operation temperature

- Is the TEC connected properly to the front connector?
 - Check all cables.
 - Check the correct polarity (see section 1.7.9, "Polarity check of the TEC element", page 24)

- Is the temperature sensor connected properly and are his parameters entered correctly?
 - Check the corresponding connections and polarities of the temperature sensor (refer to chapters 1.7.5, to 1.7.7)
 - Check the software-settings in the channel menu
 - Select the corresponding temperature sensor.
 - Enter the right set-values for resistance (Rs,R0) and Temperature (T0)

- ◆ Set temperature differs from actual temperature (of the laser)
 - Is the sensor calibrated properly?
 - Enter precise calibration factors (thermistor). Refer to section 2.2.7.

If you don't find the error source by means of the trouble shooting list or if more modules work erratic please first connect the [Thorlabs-Hotline \(blueline@thorlabs.com\)](mailto:blueline@thorlabs.com) before sending the whole PRO8000 (-4) / PRO800 system for checkup and repair to [Thorlabs-Germany](#).

(refer to section 5.4, "Addresses " on page 93

5 Listings

5.1 List of acronyms

The following acronyms and abbreviations are used in this manual:

ADC	<u>A</u> nalog to <u>D</u> igital <u>C</u> onverter
ASCII	<u>A</u> merican <u>S</u> tandard <u>C</u> ode for <u>I</u> nformation <u>I</u> nterchange
CLR	<u>C</u> Lea <u>R</u>
CR	<u>C</u> arriage <u>R</u> eturn
CRD	<u>C</u> haracter <u>R</u> esponse <u>D</u> ata
DAC	<u>D</u> igital to <u>A</u> nalog <u>C</u> onverter
D-Share	<u>D</u> ifferential share
DCL	<u>D</u> evice <u>C</u> lear
DEC	<u>D</u> evice <u>E</u> rror <u>C</u> ondition Register
DEE	<u>D</u> evice <u>E</u> rror <u>E</u> vent Register
DES	<u>D</u> evice <u>E</u> rror <u>S</u> tatus
EAV	<u>E</u> rror <u>A</u> vailable
EDE	<u>E</u> nable <u>D</u> evice <u>E</u> rror Event Register
ELCH	<u>E</u> lectrical <u>C</u> haracterization
EOI	<u>E</u> nd <u>O</u> f <u>I</u> nformation
ESE	Standard <u>E</u> vent <u>S</u> tatus <u>E</u> nable register
ESR	<u>E</u> vent <u>S</u> tatus <u>R</u> egister
FIN	Command <u>F</u> INished
GET	<u>G</u> roup <u>E</u> xecute <u>T</u> rigger
GTL	<u>G</u> o <u>T</u> o <u>L</u> ocal
GPIB	<u>G</u> eneral <u>P</u> urpose <u>I</u> nterface <u>B</u> us
IEEE	<u>I</u> nstitute for <u>E</u> lectrical and <u>E</u> lectronic <u>E</u> ngineering
I-Share	<u>I</u> ntegral share
LDC	<u>L</u> aser <u>D</u> iode <u>C</u> ontroller
LED	<u>L</u> ight <u>E</u> mitting <u>D</u> iode
LF	<u>L</u> ine <u>F</u> eed
LLO	<u>L</u> ocal <u>L</u> ockout
NR1	<u>N</u> umeric <u>R</u> esponse data of type <u>1</u>
NR2	<u>N</u> umeric <u>R</u> esponse data of type <u>2</u>
NR3	<u>N</u> umeric <u>R</u> esponse data of type <u>3</u>
MAV	<u>M</u> essage <u>A</u> vailable)

MSS	<u>M</u> aster <u>S</u> ummary <u>S</u> tatus
OTP	<u>O</u> ver <u>T</u> em <u>P</u> erature
PC	<u>P</u> ersonal <u>C</u> omputer
P-Share	<u>P</u> roportional share
RQS	<u>R</u> e <u>Q</u> uest <u>S</u> ervice Message
SDC	<u>S</u> electe <u>D</u> <u>D</u> evice <u>C</u> lear
SEL	<u>S</u> E <u>L</u> ect
SRE	<u>S</u> ervice <u>R</u> equest <u>E</u> nable Register
SRQ	<u>S</u> ervice <u>R</u> e <u>Q</u> uest
STB	<u>S</u> <u>T</u> atus <u>B</u> yte Register
SW	<u>S</u> oft <u>W</u> are
TEC	<u>T</u> hermo <u>E</u> lectric <u>C</u> ooler (Peltier Element)
TRG	<u>T</u> Ri <u>G</u> ger

5.2 List of figures

Figure 1	The ITC8xxx front panel	13
Figure 2	Pin assignment of the laser diode connector (female).....	17
Figure 3	Pin assignments of laser- and photodiode	19
Figure 4	Pin assignment of the TEC connector (female).....	21
Figure 5	Connecting a thermistor	22
Figure 6	Connecting an AD590	22
Figure 7	Connecting an LM335	23
Figure 8	Connecting a TEC element	23
Figure 9	ITC8000-DS15 D-SUB I/O jack (female).....	25
Figure 10	Principle set-up of laser temperature control.....	26
Figure 11	The TED 8xxx device error registers DEC, DEE and EDE	77
Figure 12	The PRO8000 (-4) / PRO800 register ESR, ESE, STB and SRE ...	78

5.3 Certifications and compliances

Certifications and compliances

Category	Standards or description	
EC Declaration of Conformity - EMC	Meets intent of Directive 89/336/EEC for Electromagnetic Compatibility. Compliance was demonstrated to the following specifications as listed in the Official Journal of the European Communities:	
	EN 61326	EMC requirements for Class A electrical equipment for measurement, control and laboratory use, including Class A Radiated and Conducted Emissions ^{1,2,3} and Immunity. ^{1,2,4}
	IEC 61000-4-2	Electrostatic Discharge Immunity (Performance criterion C)
	IEC 61000-4-3	Radiated RF Electromagnetic Field Immunity (Performance criterion B)
	IEC 61000-4-4	Electrical Fast Transient / Burst Immunity (Performance criterion C)
	IEC 61000-4-5	Power Line Surge Immunity (Performance criterion C)
	IEC 61000-4-6	Conducted RF Immunity (Performance criterion B)
	IEC 61000-4-11	Voltage Dips and Interruptions Immunity (Performance criterion C)
	EN 61000-3-2	AC Power Line Harmonic Emissions
Australia / New Zealand Declaration of Conformity - EMC	Complies with the Radiocommunications Act and demonstrated per EMC Emission standard ^{1,2,3} .	
	AS/NZS 2064	Industrial, Scientific, and Medical Equipment: 1992
FCC EMC Compliance	Emissions comply with the Class A Limits of FCC Code of Federal Regulations 47, Part 15, Subpart B ^{1,2,3} .	

¹ Compliance demonstrated using high-quality shielded interface cables, including with CAB4x series cables installed at the LD OUT and TEC OUT ports. ITC8022 testing included a LAB8000 Laser Diode Mount Box attached at the other end of the CAB4x cable.

² Compliance demonstrated with the ITC8x series modules installed in Thorlabs PRO8x series mainframes.

³ Emissions, which exceed the levels required by these standards, may occur when this equipment is connected to a test object.

⁴ Minimum Immunity Test requirement.

5.4 Addresses

Thorlabs GmbH

Gauss-Strasse 11
D-85757 Karlsfeld
Fed. Rep. of Germany

Tel.: +49 (0)81 31 / 5956-0
Fax: +49 (0)81 31 / 5956 99

Email: profile@thorlabs.com
Internet: <http://www.thorlabs.com>
Technical Hotline: blueline@thorlabs.com

Our company is also represented by several distributors and sales offices throughout the world.

Please call our hotline, send an E-mail to ask for your nearest distributor or just visit our homepage <http://www.thorlabs.com>